

Flange

SAE

SAE Flanges
Brides SAE
SAE flansche



CATALOGO - FSAE 03/03 - 1

Catalogue
Catalogue
Katalog



■ Officine Meccaniche
cioooda s.r.l.



FLANGIA FILETTATA GAS

BSP thread flange
Brides SAE taraudées BSP
Einschraubflansch

FLANGIA FILETTATA NPT

NPT thread flange
Brides SAE taraudées NPT
Einschraubflansch NPT

FLANGIA A SALDARE DI TASCA

Socket weld flange
Bride à emmanchement
Einlötfansch

FLANGIA A SALDARE DI TESTA

Butt weld flange
Bride bout à bout
Anschweißflansch

FLANGIA FILETTO CILINDRICO U.N. con sedi OR

UNF cylindrical thread flange with O-ring groove
Bride taraudée UNF
SAE-Gewindeflansch mit UNF-Gewinde

FLANGIA FILETTO CILINDRICO METRICO con sede OR

Metric cylindrical thread flange with O-ring groove
Bride taraudée métriques
SAE-Gewindeflansch mit metrischem Gewinde

CONTROFLANGIA FILETTATA GAS

Counter flanges with BSP thread
Contre bride taraudée BSP
Gegenflanschverbinder mit Gewinde

CONTROFLANGIA A SALDARE DI TASCA

Counter flanges socket weld
Contre bride à emmanchement
Gegenflanschverbinder zum Einlöten

CONTROFLANGIA A SALDARE DI TESTA

Counter flanges butt weld
Contre bride bout à bout
Gegenflanschverbinder zum Anschweißen

DOPPIA FLANGIA FILETTATA GAS

Double flanges BSP threaded
Double bride taraudée BSP
Doppelflanschverbinder mit Gewinde

DOPPIA FLANGIA A SALDARE DI TASCA

Double flanges socket weld
Double bride à emmanchement
Doppelflanschverbinder zum Einlöten

DOPPIA FLANGIA A SALDARE DI TESTA

Double flanges butt weld
Double bride bout à bout
Doppelflanschverbinder zum Anschweißen

FLANGIA CIECA

Closed flanges
Bride d'obturation
Verschlußflansch

FLANGIA PIATTA A SALDARE

Socket welding flat flange
Bride plat à emmanchement
Einschweißflanschflache Bauform

FLANGIA PIATTA FILETTATA

Threaded flat flange
Bride plat taraudée
Gewindeflanschflache Bauform

FLANGIA DI CHIUSURA / PROTEZIONE

Locking / protection Flange
Bride de fermeture / protection
Abschlußplatte

FLANGIA DI CONNESSIONE

Connector Flange
Bride de liaison
Zwischenplatte

FLANGIA A 90° FILETTATA GAS

90° Flanges with BSP thread
Bride à 90° taraudée BSP
90° Flanschverbinder mit Gewinde

FLANGIA A 90° FILETTATA NPT

NPT 90° Flanges
Bride à 90° taraudée NPT
90° Einschraubflansch NPT

FLANGIA A 90° A SALDARE DI TASCA

90° Flanges socket weld
Bride à 90° à emmanchement
90° Flanschverbinder zum Einschweißen

FLANGIA A 90° A SALDARE DI TESTA

90° Flanges butt welding
Bride à 90° bout à bout
90° - Winkel-Anschweißflansch

FLANGIA DRITTA CON ATTACCO JIC

Straight flanges to male JIC
Bride taraudée JIC
Gerader Flansch mit JIC-Außengewinde

FLANGIA A 90° CON ATTACCO JIC

90° Flanges to male JIC
Bride à 90° taraudée JIC
90° Winkelflansch mit JIC-Außengewinde

FLANGIA DRITTA FILETTATA GAS ESTERNO

Straight flanges to BSP male
Bride taraudée BSP mâle
Gerader Flansch mit BSP-Außengewinde

FLANGIA A 90° FILETTATA GAS ESTERNO

90° Flanges to BSP male
Bride à 90° taraudée BSP mâle
90° Winkelflansch mit BSP-Außengewinde

FLANGIA FILETTATA METRICA DIN 2353

Flanges with metric thread according with DIN 2353
Bride taraudée métrique DIN 2353
Gerader Flansch mit Schneidring-Anschluß nach DIN 2353

FLANGIA A 90° FILETTATA METRICA DIN 2353

90° Flanges with metric thread in according with DIN 2353
Bride à 90° taraudée métrique DIN 2353
90° Winkelflansch mit Schneidring-Anschluß nach DIN 2353

FLANGIA DRITTA TENUTA FRONTALE ORFS

Straight flanges O-Ring face seal
Bride ORFS
Gerader Flansch O-Ring flachdichtend

FLANGIA A 90° TENUTA FRONTALE OR

90° Flange O-Ring face seal
Bride à 90° ORFS
90° - Flansch O-Ring flachdichtend

ADATTATORE S.A.E.

S.A.E. Straight adapter flange
Adaptateur S.A.E.
S.A.E. Reduzier flansch gerade

BLOCCO S.A.E. 90° L

S.A.E. - 90° L - Block
Bloc S.A.E. à 90°
S.A.E. 90° L - Block

BLOCCO S.A.E. 90° L RIDOTTO

S.A.E. 90° L reduction
Bloc S.A.E. à 90° réduit
S.A.E. 90° L Reduzierblock

BLOCCO S.A.E. A T

S.A.E. T - Block
Bloc S.A.E. à T
S.A.E. T - Block

BLOCCO S.A.E. A T PER FLANGE

S.A.E. T block counter flange
Contre bloc S.A.E. à T
S.A.E. T block gegenflanschausführung

FLANGIE S.A.E. PER CONTROLLO DI PRESSIONE

Chek pressure S.A.E. flange
Bride S.A.E. pour le contrôle de la pression
S.A.E.-Zwischenflansch mit Messanschluss

FLANGE E CONTROFLANGE S.A.E. con foro controllo pressione

S.A.E. flanges and counterflanges with hole to chek pressure on
Bride et contre bride S.A.E. avec trou de contrôle de pression
S.A.E. flansch und Gegenflansch mit Messanschluss

FLANGE OVALI

Oval flanges
Bride Ovale
Ovale flansche

FLANGIA FILETTATA GAS

BSP thread flange
Brides SAE taraudées BSP
Einschraubflansch

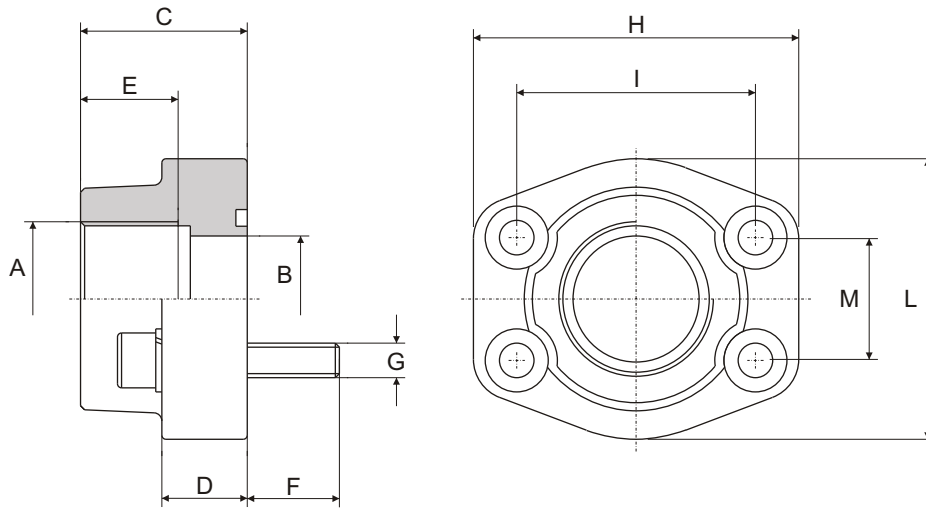

serie 3000 psi

Pressione max esercizio bar	Tipo Type	A S.A.E.	B	C	D	E	F	G Viti / Bolts		H	I	L	M	OR O-RING
								Metr.	UNC					
348	C.F.S. 080-GAS	3/8"	13	36	16	13	14	M 8	5/16"	57	38	47	17,5	4075
348	C.F.S. 080-GAS	1/2"	13	36	16	15	14	M 8	5/16"	57	38	47	17,5	4075
348	C.F.S. 100-GAS	3/4"	19	36	18	18	16	M10	3/8"	66	47,6	49	22,2	4100
348	C.F.S. 102-GAS	1"	25	38	18	20	16	M10	3/8"	71	52,4	53	26,2	4131
278	C.F.S. 104-GAS	1" 1/4	31	41	21	22	18	M10	7/16"	80	58,7	69	30,2	4150
210	C.F.S. 106-GAS	1" 1/2	38	44	25	24	18	M12	1/2"	94	69,85	77	35,7	4187
210	C.F.S. 108-GAS	2"	50	45	25	26	18	M12	1/2"	103	77,8	89	42,9	4225
175	C.F.S. 110-GAS	2" 1/2	63	50	25	30	18	M12	1/2"	115	89	101	50,8	4275
138	C.F.S. 112-GAS	3"	73	50	27	30	25	M16	5/8"	135	106,4	124	62	4337
35	C.F.S. 114-GAS	3" 1/2	89	50	27	30	25	M16	5/8"	152	120,7	136	70	4387
35	C.F.S. 116-GAS	4"	99	50	27	30	25	M16	5/8"	162	130	146	77,8	4437
35	C.F.S. 118-GAS	5"	120	50	28	30	25	M16	5/8"	184	152,4	180	92	4537

serie 6000 psi

Pressione max esercizio bar	Tipo Type	A S.A.E.	B	C	D	E	F	G Viti / Bolts		H	I	L	M	OR O-RING
								Metr.	UNC					
420	C.F.S. 401-GAS	3/8"	13	36	16	13	14	M 8	5/16"	57	40,5	47	18,3	4075
420	C.F.S. 401-GAS	1/2"	13	36	16	15	14	M 8	5/16"	57	40,5	47	18,3	4075
420	C.F.S. 402-GAS	3/4"	19	36	19	18	16	M10	3/8"	71	50,8	53	23,8	4100
420	C.F.S. 403-GAS	1"	25	44	24	20	19	M12	7/16"	80	57,1	69	27,8	4131
420	C.F.S. 404-GAS	1" 1/4	31	44	27	22	22	M14	1/2"	94	66,7	77	31,6	4150
420	C.F.S. 405-GAS	1" 1/2	38	51	30	24	24	M16	5/8"	106	79,4	89	36,5	4187
420	C.F.S. 406-GAS	2"	50	70	37	33	32	M20	3/4"	135	96,8	116	44,4	4225
420	C.F.S. 408-GAS	2" 1/2	63	75	45	35	40	M24	-	166	123,8	150	58,7	4275
420	C.F.S. 410-GAS	3"	73	90	55	40	55	M30	-	208	152,4	178	71,4	4337

Per ordinazione flange: / Ordering Examples: / Pour commander brides: / Bestellbeispiel für Flansche:

Solo flangia.....CFS...G Flangia completa di viti UNC, rondelle e OR.....CFS...G-U Flangia completa di viti metriche, rondelle e OR.....CFS...G-M
 Only flange.....CFS...G Complete flange with UNC screws, washers and o-ring.....CFS...G-U Complete flange with metric screws, washers and o-ring.....CFS...G-M
 Seulement bride..CFS...G Bride complete des vis UNC, rondelles et OR.....CFS...G-U Bride complete des vis métriques, rondelles et OR.....CFS...G-M
 Nur Flansch.....CFS...G Flansch einschl. UNC-Schrauben, Federringen und O-Ring..CFS...G-U Flansch einschl. metrischen Zylinderschrauben, Federringen und O-Ring..CFS...G-M

FLANGIA FILETTATA NPT

NPT thread flange
Brides SAE taraudées NPT
Einschraubflansch NPT

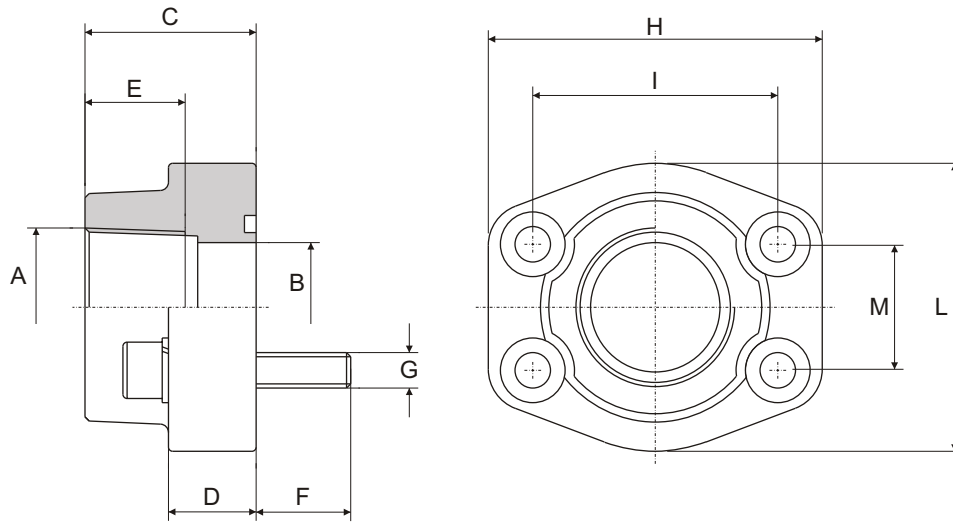

serie 3000 psi

Pressione max esercizio bar	Tipo Type	A S.A.E.	B	C	D	E	F	G Viti / Bolts		H	I	L	M	OR O-RING
								Metr.	UNC					
348	C.F.S. 080-NPT	3/8"	13	36	16	19	14	M 8	5/16"	57	38	47	17,5	4075
348	C.F.S. 080-NPT	1/2"	13	36	16	19	14	M 8	5/16"	57	38	47	17,5	4075
348	C.F.S. 100-NPT	3/4"	19	36	18	19	16	M10	3/8"	66	47,6	49	22,2	4100
348	C.F.S. 102-NPT	1"	25	38	18	19	16	M10	3/8"	71	52,4	53	26,2	4131
278	C.F.S. 104-NPT	1" 1/4	31	41	21	22	18	M10	7/16"	80	58,7	69	30,2	4150
210	C.F.S. 106-NPT	1" 1/2	38	44	25	24	18	M12	1/2"	94	69,85	77	35,7	4187
210	C.F.S. 108-NPT	2"	50	45	25	26	18	M12	1/2"	103	77,8	89	42,9	4225
175	C.F.S. 110-NPT	2" 1/2	63	50	25	30	18	M12	1/2"	115	89	101	50,8	4275
138	C.F.S. 112-NPT	3"	73	50	27	34	25	M16	5/8"	135	106,4	124	62	4337
35	C.F.S. 114-NPT	3" 1/2	89	50	27	36	25	M16	5/8"	152	120,7	136	70	4387
35	C.F.S. 116-NPT	4"	99	50	27	36	25	M16	5/8"	162	130	146	77,8	4437
35	C.F.S. 118-NPT	5"	120	50	28	36	25	M16	5/8"	184	152,4	180	92	4537

serie 6000 psi

Pressione max esercizio bar	Tipo Type	A S.A.E.	B	C	D	E	F	G Viti / Bolts		H	I	L	M	OR O-RING
								Metr.	UNC					
420	C.F.S. 401-NPT	3/8"	13	36	16	19	14	M 8	5/16"	57	40,5	47	18,3	4075
420	C.F.S. 401-NPT	1/2"	13	36	16	19	14	M 8	5/16"	57	40,5	47	18,3	4075
420	C.F.S. 402-NPT	3/4"	19	36	19	22	16	M10	3/8"	71	50,8	53	23,8	4100
420	C.F.S. 403-NPT	1"	25	44	24	24	19	M12	7/16"	80	57,1	69	27,8	4131
420	C.F.S. 404-NPT	1" 1/4	31	44	27	25	22	M14	1/2"	94	66,7	77	31,6	4150
420	C.F.S. 405-NPT	1" 1/2	38	51	30	28	24	M16	5/8"	106	79,4	89	36,5	4187
420	C.F.S. 406-NPT	2"	50	70	37	33	32	M20	3/4"	135	96,8	116	44,4	4225
420	C.F.S. 408-NPT	2" 1/2	63	75	45	35	40	M24	-	166	123,8	150	58,7	4275
420	C.F.S. 410-NPT	3"	73	90	55	40	55	M30	-	208	152,4	178	71,4	4337

Per ordinazione flange: / Ordering Examples: / Pour commander brides: / Bestellbeispiel für Flansche:

Solo flangia..... CFS...N	Flangia completa di viti UNC, rondelle e OR.....CFS...N-U	Flangia completa di viti metriche, rondelle e OR.....CFS...N-M
Only flange..... CFS...N	Complete flange with UNC screws, washers and o-ring.....CFS...N-U	Complete flange with metrical screws, washers and o-ring.....CFS...N-M
Seulement bride... CFS...N	Bride complete des vis UNC, rondelles et OR.....CFS...N-U	Bride complete des vis métriques, rondelles et OR.....CFS...N-M
Nur Flansch..... CFS...N	Flansch einschl. UNC-Schrauben, Federringen und O-Ring..CFS...N-U	Flansch einschl. metrischen Zylinderschrauben, Federringen und O-Ring.. CFS...N-M

FLANGIA A SALDARE DI TASCA

Socket weld flange
Bride à emmanchement
Einlötflansch

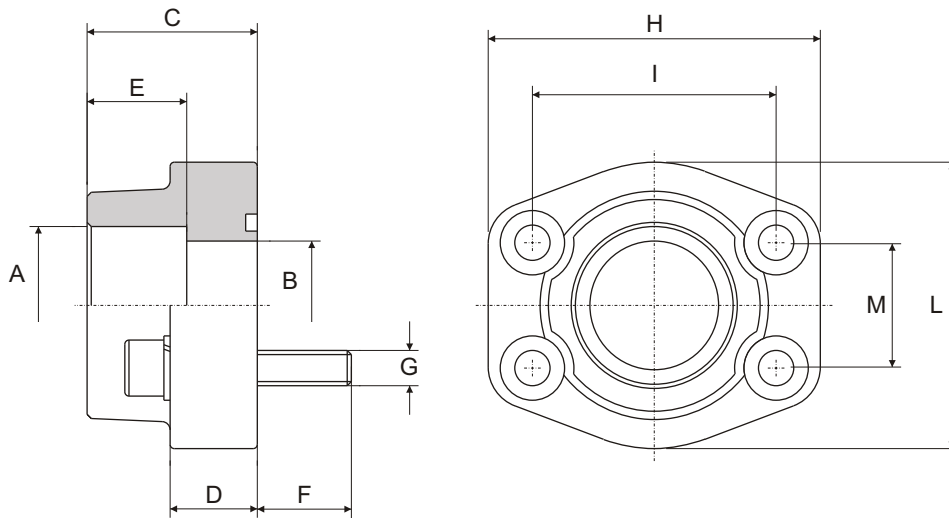

serie 3000 psi

Pressione max esercizio bar	Tipo Type	A	S.A.E.	B	C	D	E	F	G Viti / Bolts		H	I	L	M	OR O-RING
									Metr.	UNC					
348	C.F.S. 080-S	17,5	3/8"	13	36	16	18	14	M 8	5/16"	57	38	47	17,5	4075
348	C.F.S. 080-S	21,6	1/2"	13	36	16	18	14	M 8	5/16"	57	38	47	17,5	4075
348	C.F.S. 100-S	27,2	3/4"	19	36	18	18	16	M10	3/8"	66	47,6	49	22,2	4100
348	C.F.S. 102-S	34,1	1"	25	38	18	18	16	M10	3/8"	70	52,4	53	26,2	4131
278	C.F.S. 104-S	42,8	1 1/4"	31	41	21	20	18	M10	7/16"	80	58,7	69	30,2	4150
210	C.F.S. 106-S	48,6	1 1/2"	38	44	25	22	18	M12	1/2"	94	69,85	77	35,7	4187
210	C.F.S. 108-S	61	2"	50	45	25	24	18	M12	1/2"	103	77,8	89	42,9	4225
175	C.F.S. 110-S	76,6	2 1/2"	63	50	25	28	18	M12	1/2"	115	89	101	50,8	4275
138	C.F.S. 112-S	90,5	3"	73	50	27	28	25	M16	5/8"	135	106,4	124	62	4337
35	C.F.S. 114-S	103	3 1/2"	89	50	27	28	25	M16	5/8"	153	120,7	137	70	4387
35	C.F.S. 116-S	115,5	4"	99	50	27	28	25	M16	5/8"	163	130	147	77,8	4437
35	C.F.S. 118-S	142	5"	120	50	28	28	25	M16	5/8"	184	152,4	180	92	4537

serie 6000 psi

Pressione max esercizio bar	Tipo Type	A	S.A.E.	B	C	D	E	F	G Viti / Bolts		H	I	L	M	OR O-RING
									Metr.	UNC					
420	C.F.S. 401-S	17,5	3/8"	13	36	16	18	14	M 8	5/16"	57	40,5	47	18,3	4075
420	C.F.S. 401-S	21,6	1/2"	13	36	16	18	14	M 8	5/16"	57	40,5	47	18,3	4075
420	C.F.S. 402-S	27,2	3/4"	19	36	19	20	16	M10	3/8"	71	50,8	53	23,8	4100
420	C.F.S. 403-S	34,1	1"	25	44	24	22	19	M12	7/16"	80	57,1	66	27,8	4131
420	C.F.S. 404-S	42,8	1 1/4"	31	44	27	22	22	M14	1/2"	94	66,7	77	31,6	4150
420	C.F.S. 405-S	48,6	1 1/2"	38	51	30	24	24	M16	5/8"	106	79,4	89	36,5	4187
420	C.F.S. 406-S	61	2"	50	70	37	25	32	M20	3/4"	135	96,8	116	44,4	4225
420	C.F.S. 408-S	76,6	2 1/2"	63	75	45	28	40	M24	-	166	123,8	150	58,7	4275
420	C.F.S. 410-S	90,5	3"	73	90	55	30	55	M30	-	208	152,4	178	71,4	4337

Per ordinazione flange: / Ordering Examples: / Pour commander brides: / Bestellbeispiel für Flansche:

Solo flangia..... CFS...S Flangia completa di viti UNC, rondelle e OR..... CFS...S-U Flangia completa di viti metriche, rondelle e OR..... CFS...S-M
 Only flange..... CFS...S Complete flange with UNC screws, washers and o-ring..... CFS...S-U Complete flange with metrical screws, washers and o-ring..... CFS...S-M
 Seulement bride... CFS...S Bride complete des vis UNC, rondelles et OR..... CFS...S-U Bride complete des vis métriques, rondelles et OR..... CFS...S-M
 Nur Flansch..... CFS...S Flansch einschl. UNC-Schrauben, Federringen und O-Ring... CFS...S-U Flansch einschl. metrischen Zylinderschrauben, Federringen und O-Ring... CFS...S-M

FLANGIA A SALDARE DI TESTA

Butt weld flange
Bride bout à bout
Anschweißflansch

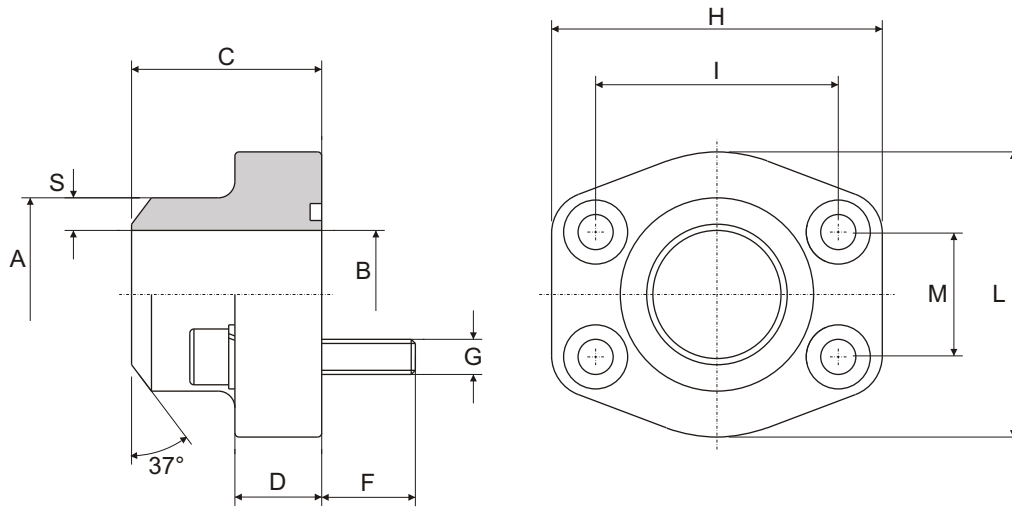

serie 3000 psi

Pressione max esercizio bar	Tipo Type	A	S.A.E.	B	C	D	S	F	G Viti / Bolts		H	I	L	M	OR O-RING
									Metr.	UNC					
348	C.F.S. 080-ST	21,6	1/2"	13	36	16	4,3	14	M 8	5/16"	57	38	47	17,5	4075
348	C.F.S. 100-ST	27,2	3/4"	19	36	18	4,1	16	M10	3/8"	66	47,6	49	22,2	4100
348	C.F.S. 102-ST	34,5	1"	25	38	18	4,7	16	M10	3/8"	71	52,4	53	26,2	4131
278	C.F.S. 104-ST	42,8	1" 1/4	31	41	21	6	18	M10	7/16"	80	58,7	69	30,2	4150
210	C.F.S. 106-ST	48,6	1" 1/2	38	44	25	5,3	18	M12	1/2"	94	69,85	77	35,7	4187
210	C.F.S. 108-ST	61	2"	50	45	25	5,5	18	M12	1/2"	103	77,8	89	42,9	4225
175	C.F.S. 110-ST	76,6	2" 1/2	63	50	25	6,8	18	M12	1/2"	115	89	101	50,8	4275
138	C.F.S. 112-ST	89	3"	73	50	27	8	25	M16	5/8"	135	106,4	124	62	4337
35	C.F.S. 114-ST	103	3" 1/2	89	50	27	7	25	M16	5/8"	153	120,7	137	70	4387
35	C.F.S. 116-ST	115	4"	99	50	27	8	25	M16	5/8"	163	130	147	77,8	4437
35	C.F.S. 118-ST	141	5"	120	50	28	10,5	25	M16	5/8"	184	152,4	180	92	4537

serie 6000 psi

Pressione max esercizio bar	Tipo Type	A	S.A.E.	B	C	D	S	F	G Viti / Bolts		H	I	L	M	OR O-RING
									Metr.	UNC					
420	C.F.S. 401-ST	17,5	3/8"	10	36	18	3,7	14	M 8	5/16"	57	40,5	47	18,3	4075
420	C.F.S. 401-ST	21,6	1/2"	13	36	18	4,3	14	M 8	5/16"	57	40,5	47	18,3	4075
420	C.F.S. 402-ST	27,2	3/4"	18	36	18	4,6	16	M10	3/8"	71	50,8	53	23,8	4100
420	C.F.S. 403-ST	34,5	1"	22	44	24	6,3	19	M12	7/16"	80	57,1	66	27,8	4131
420	C.F.S. 404-ST	42,8	1" 1/4	28	44	25	7,4	22	M14	1/2"	94	66,7	77	31,6	4150
420	C.F.S. 405-ST	48,6	1" 1/2	32	51	29	8,3	24	M16	5/8"	106	79,4	89	36,5	4187
420	C.F.S. 406-ST	61	2"	41	70	35	10	32	M20	3/4"	135	96,8	116	44,4	4225
420	C.F.S. 408-ST	76,6	2" 1/2	50	75	45	13	40	M24	-	166	123,8	150	58,7	4275
420	C.F.S. 410-ST	90	3"	58	90	55	16	55	M30	-	208	152,4	178	71,4	4337

Per ordinazione flange: / Ordering Examples: / Pour commander brides: / Bestellbeispiel für Flansche:

Solo flangia..... CFS...ST	Flangia completa di viti UNC, rondelle e OR..... CFS...ST-U	Flangia completa di viti metriche, rondelle e OR..... CFS...ST-M
Only flange..... CFS...ST	Complete flange with UNC screws, washers and o-ring..... CFS...ST-U	Complete flange with metrical screws, washers and o-ring..... CFS...ST-M
Seulement bride... CFS...ST	Bride complete des vis UNC, rondelles et OR..... CFS...ST-U	Bride complete des vis métriques, rondelles et OR..... CFS...ST-M
Nur Flansch..... CFS...ST	Flansch einschl. UNC-Schrauben, Federringen und O-Ring... CFS...ST-U	Flansch einschl. metrischen Zylinderschrauben, Federringen und O-Ring... CFS...ST-M

FLANGIA FILETTO CILINDRICO U.N. con sedi OR

**UNF cylindrical thread
flange with O-ring groove
Bride taraudée UNF
SAE-Gewindeflansch mit UNF-Géwinde**

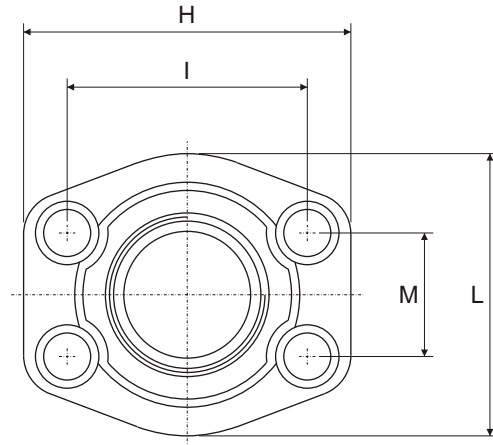
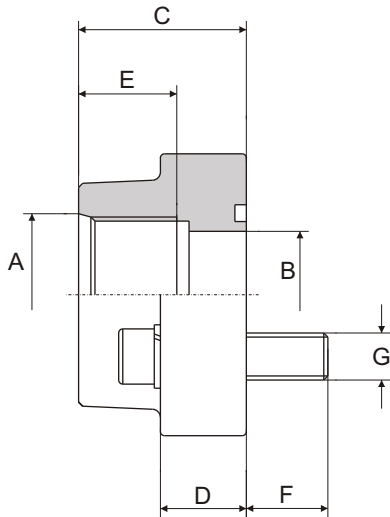

A richiesta si possono fornire le controflange con fori filettati senza sede OR
On request can be supplied counter-flanges with tapholes, without O-ring groove
Sur demande on peut fournir les controbriques avec les trous taraudés sans siège OR
Auf Wunsch auch als Gegenflansch ohne O-ring Nut mit Befestigungsbohrungen lieferbar

serie 3000 psi

Pressione max esercizio bar	Tipo Type	A S.A.E.	B	C	D	E	F	G Viti / Bolts		H	I	L	M	OR O-RING
								Metr.	UNC					
348	U.N. 080-A	3/4"-16	13	36	16	17	14	M 8	5/16"	57	38	47	17,5	4075
348	U.N. 100-A	7/8"-14	19	36	18	17	16	M10	3/8"	66	47,6	49	22,2	4100
	U.N. 100-B	1" 1/16-12												
348	U.N. 102-A	1" 1/16-12	25	38	18	23	16	M10	3/8"	71	52,4	53	26,2	4131
	U.N. 102-B	1" 5/16-12												
278	U.N. 104-A	1" 5/16-12	31	41	21	23	18	M10	7/16"	80	58,7	69	30,2	4150
	U.N. 104-B	1" 5/8-12												
210	U.N. 106-A	1" 5/8-12	38	44	25	23	18	M12	1/2"	94	69,85	77	35,7	4187
	U.N. 106-B	1" 7/8-12												

serie 6000 psi

Pressione max esercizio bar	Tipo Type	A S.A.E.	B	C	D	E	F	G Viti / Bolts		H	I	L	M	OR O-RING
								Metr.	UNC					
420	U.N. 401-A	3/4"-16	13	36	16	17	14	M 8	5/16"	57	40,5	47	18,3	4075
420	U.N. 402-A	7/8"-14	19	36	19	17	16	M10	3/8"	71	50,8	53	23,8	4100
	U.N. 402-B	1" 1/16-12												
420	U.N. 403-A	1" 1/16-12	25	44	24	23	19	M12	7/16"	80	57,1	69	27,8	4131
	U.N. 403-B	1" 5/16-12												
420	U.N. 404-A	1" 5/16-12	31	44	27	23	22	M14	1/2"	94	66,7	77	31,6	4150
	U.N. 404-B	1" 5/8-12												
420	U.N. 405-A	1" 5/8-12	38	51	30	23	24	M16	5/8"	106	79,4	89	36,5	4187
	U.N. 405-B	1" 7/8-12												

Per ordinazione flange: / Ordering Examples: / Pour commander brides: / Bestellbeispiel für Flansche:

Solo flangia..... UNF...AB Flangia completa di viti UNC, rondelle e OR..... UNF...AB-U Flangia completa di viti metriche, rondelle e OR..... UNF...AB-M
 Only flange..... UNF...AB Complete flange with UNC screws, washers and o-ring..... UNF...AB-U Complete flange with metrical screws, washers and o-ring..... UNF...AB-M
 Seulement bride... UNF...AB Bride complete des vis UNC, rondelles et OR..... UNF...AB-U Bride complete des vis métriques, rondelles et OR..... UNF...AB-M
 Nur Flansch..... UNF...AB Flansch einschl. UNC-Schrauben, Federringen und O-Ring... UNF...AB-U Flansch einschl. metrischen Zylinderschrauben, Federringen und O-Ring... UNF...AB-M

FLANGIA FILETTO CILINDRICO METRICO

con sede OR

— Metric cylindrical thread flange with O-ring groove
Bride taraudée métriques
SAE-Gewindeflansch mit metrischem Gewinde

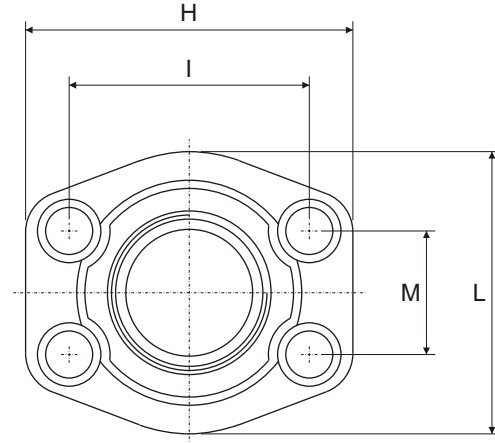
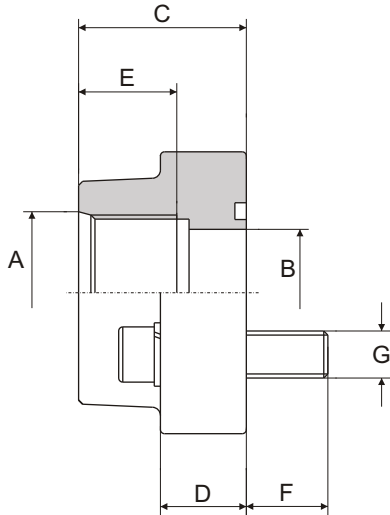

A richiesta si possono fornire le controflange con fori filettati senza sede OR
On request can be supplied counter-flanges with tapholes, without O-ring groove
Sur demande on peut fournir les controbriques avec les trous taraudés sans siège OR
Auf Wunsch auch als Gegenflansch ohne O-ring Nut mit Befestigungsböhrungen lieferbar

serie 3000 psi

Pressione max esercizio bar	Tipo Type	S.A.E.	A	B	C	D	E	F	G Viti / Bolts		H	I	L	M	OR O-RING
									Metr.	UNC					
348	MET. 080-A MET. 080-B	1/2"	18x1,5 20x1,5	13	36	16	15	14	M 8	5/16"	57	38	47	17,5	4075
348	MET. 100-A MET. 100-B	3/4"	22x1,5 27x2	19	36	18	16 19	16	M10	3/8"	66	47,6	49	22,2	4100
348	MET. 102-A MET. 102-B	1"	27x2 33x2	25	38	18	19 19	16	M10	3/8"	71	52,4	53	26,2	4131
278	MET. 104-A MET. 104-B	1" 1/4	33x2 42x2	31	41	21	19 20	18	M10	7/16"	80	58,7	69	30,2	4150
210	MET. 106-A MET. 106-B	1" 1/2	42x2 48x2	38	44	25	20 22	18	M12	1/2"	94	69,85	77	35,7	4187

serie 6000 psi

Pressione max esercizio bar	Tipo Type	S.A.E.	A	B	C	D	E	F	G Viti / Bolts		H	I	L	M	OR O-RING
									Metr.	UNC					
420	MET. 401-A MET. 401-B	1/2"	18x1,5 20x1,5	13	36	16	15	14	M 8	5/16"	57	40,5	47	18,3	4075
420	MET. 402-A MET. 402-B	3/4"	22x1,5 27x2	19	36	19	16 19	16	M10	3/8"	71	50,8	53	23,8	4100
420	MET. 403-A MET. 403-B	1"	27x2 33x2	25	44	24	19 19	19	M12	7/16"	80	57,1	69	27,8	4131
420	MET. 404-A MET. 404-B	1" 1/4	33x2 42x2	31	44	27	19 20	22	M14	1/2"	94	66,7	77	31,6	4150
420	MET. 405-A MET. 405-B	1" 1/2	42x2 48x2	38	51	30	20 22	24	M16	5/8"	106	79,4	89	36,5	4187

Per ordinazione flange: / Ordering Examples: / Pour commander brides: / Bestellbeispiel für Flansche:

Solo flangia..... MET...AB Flangia completa di viti UNC, rondelle e OR..... MET...AB-U Flangia completa di viti metriche, rondelle e OR..... MET...AB-M
Only flange..... MET...AB Complete flange with UNC screws, washers and o-ring..... MET...AB-U Complete flange with metrical screws, washers and o-ring..... MET...AB-M
Seulement bride... MET...AB Bride complete des vis UNC, rondelles et OR..... MET...AB-U Bride complete des vis métriques, rondelles et OR..... MET...AB-M
Nur Flansch..... MET...AB Flansch einschl. UNC-Schrauben, Federringen und O-Ring... MET...AB-U Flansch einschl. metrischen Zylinderschrauben, Federringen und O-Ring... MET...AB-M

CONTROFLANGIA FILETTATA GAS

Counter flanges with BSP thread
 Contre bride taraudée BSP
 Gegenflanschverbinder mit Gewinde

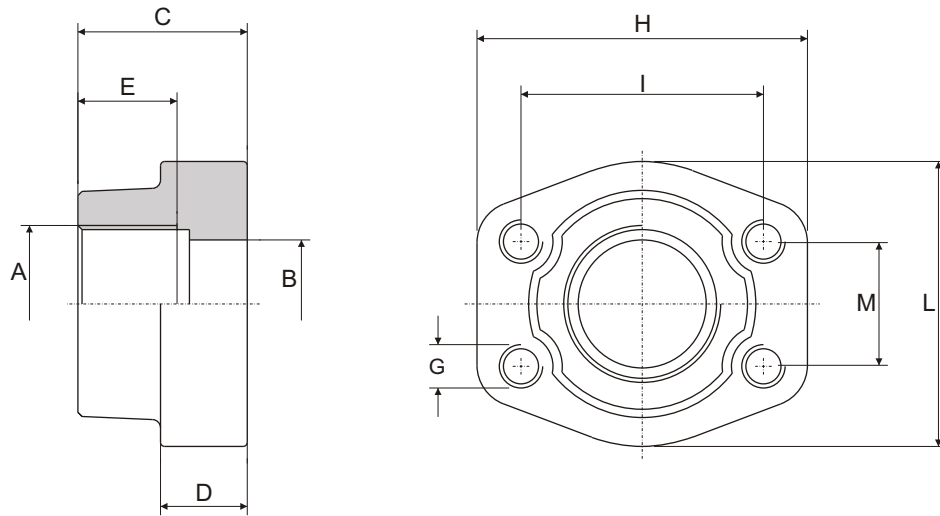

serie 3000 psi

Pressione max esercizio bar	Tipo Type	A S.A.E.	B	C	D	E	G		H	I	L	M
							Metr.	UNC				
348	C. 080-GAS-F-F	3/8"	13	36	16	19	M 8	5/16"	57	38	47	17,5
348	C. 080-GAS-F-F	1/2"	13	36	16	19	M 8	5/16"	57	38	47	17,5
348	C. 100-GAS-F-F	3/4"	19	36	18	19	M10	3/8"	66	47,6	49	22,2
348	C. 102-GAS-F-F	1"	25	38	18	19	M10	3/8"	71	52,4	53	26,2
278	C. 104-GAS-F-F	1" 1/4	31	41	21	22	M10	7/16"	80	58,7	69	30,2
210	C. 106-GAS-F-F	1" 1/2	38	44	25	24	M12	1/2"	94	69,85	77	35,7
210	C. 108-GAS-F-F	2"	50	45	25	26	M12	1/2"	103	77,8	89	42,9
175	C. 110-GAS-F-F	2" 1/2	63	50	25	30	M12	1/2"	115	89	101	50,8
138	C. 112-GAS-F-F	3"	73	50	27	34	M16	5/8"	135	106,4	124	62
35	C. 114-GAS-F-F	3" 1/2	89	50	27	27	M16	5/8"	152	120,7	136	70
35	C. 116-GAS-F-F	4"	99	50	27	30	M16	5/8"	162	130	146	77,8
35	C. 118-GAS-F-F	5"	120	50	28	30	M16	5/8"	184	152,4	180	92

serie 6000 psi

Pressione max esercizio bar	Tipo Type	A S.A.E.	B	C	D	E	G		H	I	L	M
							Metr.	UNC				
420	C. 401-GAS-F-F	3/8"	13	36	16	19	M 8	5/16"	57	40,5	47	18,3
420	C. 401-GAS-F-F	1/2"	13	36	16	19	M 8	5/16"	57	40,5	47	18,3
420	C. 402-GAS-F-F	3/4"	19	36	19	22	M10	3/8"	71	50,8	53	23,3
420	C. 403-GAS-F-F	1"	25	44	24	24	M12	7/16"	80	57,1	69	27,8
420	C. 404-GAS-F-F	1" 1/4	31	44	27	25	M14	1/2"	94	66,7	77	31,6
420	C. 405-GAS-F-F	1" 1/2	38	51	30	28	M16	5/8"	106	79,4	89	36,5
420	C. 406-GAS-F-F	2"	50	70	37	33	M20	3/4"	135	96,8	116	44,4
420	C. 408-GAS-F-F	2" 1/2	63	75	45	35	M24	-	166	123,8	150	58,7
420	C. 410-GAS-F-F	3"	73	90	55	40	M30	-	208	152,4	178	71,4

Per ordinazione flange: / Ordering Examples: / Pour commander brides: / Bestellbeispiel für Flansche:

Controflangia con fori fissaggio filettati metrici.....M-C...G-F-F
 Counter flange with metric tapholes.....M-C...G-F-F
 Contre bride avec trous taraudés metriques.....M-C...G-F-F
 Gegenflansch mit Metrischen Gewindebohrungen.....M-C...G-F-F

Controflangia con fori fissaggio filettati UNC...U-C...G-F-F
 Counter flange with UNC tapholes.....U-C...G-F-F
 Contre bride avec trous taraudés UNC.....U-C...G-F-F
 Gegenflansch mit UNC Gewindebohrungen.....U-C...G-F-F

CONTROFLANGIA A SALDARE DI TASCA

— Counter flanges socket weld
 Contre bride à emmanchement
 Gegenflanschverbinder zum Einlöten

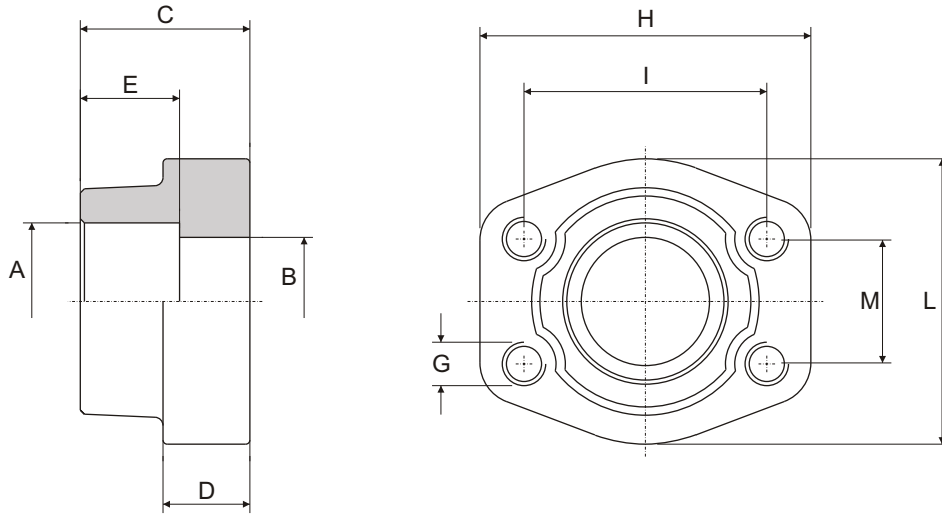

serie 3000 psi

Pressione max esercizio bar	Tipo Type	S.A.E.	A	B	C	D	E	G		H	I	L	M
								Metr.	UNC				
348	C. 080-S-F-F	3/8"	17,5	13	36	16	18	M 8	5/16"	57	38	47	17,5
348	C. 080-S-F-F	1/2"	21,6	13	36	16	18	M 8	5/16"	57	38	47	17,5
348	C. 100-S-F-F	3/4"	27,2	19	36	18	18	M10	3/8"	66	47,6	49	22,2
348	C. 102-S-F-F	1"	34,1	25	38	18	18	M10	3/8"	70	52,4	53	26,2
278	C. 104-S-F-F	1" 1/4	42,8	31	41	21	20	M10	7/16"	80	58,7	69	30,2
210	C. 106-S-F-F	1" 1/2	48,6	38	44	25	22	M12	1/2"	94	69,85	77	35,7
210	C. 108-S-F-F	2"	61	50	45	25	24	M12	1/2"	103	77,8	89	42,9
175	C. 110-S-F-F	2" 1/2	76,6	63	50	25	28	M12	1/2"	115	89	101	50,8
138	C. 112-S-F-F	3"	90,5	73	50	27	28	M16	5/8"	135	106,4	124	62
35	C. 114-S-F-F	3" 1/2	103	89	50	27	28	M16	5/8"	153	120,7	137	70
35	C. 116-S-F-F	4"	115	99	50	27	28	M16	5/8"	163	130	147	77,8
35	C. 118-S-F-F	5"	142	120	50	28	28	M16	5/8"	184	152,4	180	92

serie 6000 psi

Pressione max esercizio bar	Tipo Type	S.A.E.	A	B	C	D	E	G		H	I	L	M
								Metr.	UNC				
420	C. 401-S-F-F	3/8"	17,5	13	36	16	18	M 8	5/16"	57	40,5	47	18,3
420	C. 401-S-F-F	1/2"	21,6	13	36	16	18	M 8	5/16"	57	40,5	47	18,3
420	C. 402-S-F-F	3/4"	27,2	19	36	19	20	M10	3/8"	71	50,8	53	23,8
420	C. 403-S-F-F	1"	34,1	25	44	24	22	M12	7/16"	80	57,1	66	27,8
420	C. 404-S-F-F	1" 1/4	42,8	31	44	27	22	M14	1/2"	94	66,7	77	31,6
420	C. 405-S-F-F	1" 1/2	48,6	38	51	30	24	M16	5/8"	106	79,4	89	36,5
420	C. 406-S-F-F	2"	61	50	70	37	25	M20	3/4"	135	96,8	116	44,4
420	C. 408-S-F-F	2" 1/2	76,6	63	75	45	28	M24	-	166	123,8	150	58,7
420	C. 410-S-F-F	3"	90,5	73	90	55	30	M30	-	208	152,4	178	71,4

Per ordinazione flange: / Ordering Examples: / Pour commander brides: / Bestellbeispiel für Flansche:

Controflangia con fori fissaggio filettati metrici M-C...S-F-F
 Counter flange with metric tapholes M-C...S-F-F
 Contre bride avec trous taraudés metriques M-C...S-F-F
 Gegenflansch mit Metrischen Gewindebohrungen M-C...S-F-F

Controflangia con fori fissaggio filettati UNC U-C...S-F-F
 Counter flange with UNC tapholes U-C...S-F-F
 Contre bride avec trous taraudés UNC U-C...S-F-F
 Gegenflansch mit UNC Gewindebohrungen U-C...S-F-F

CONTROFLANGIA A SALDARE DI TESTA

— Counter flanges butt weld
 Contre bride bout à bout
 Gegenflanschverbinder zum Anschweißen

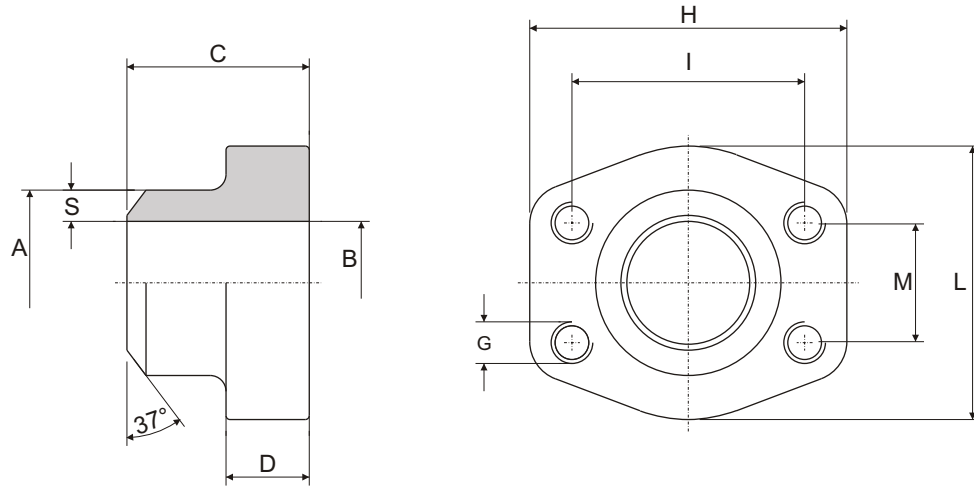

serie 3000 psi

Pressione max esercizio bar	Tipo Type	S.A.E.	A	B	C	D	S	G		H	I	L	M
								Metr.	UNC				
348	C. 080-ST-F-F	1/2"	21,6	13	36	16	4,3	M 8	5/16"	57	38	47	17,5
348	C. 100-ST-F-F	3/4"	27,2	19	36	18	4,1	M10	3/8"	66	47,6	49	22,2
348	C. 102-ST-F-F	1"	34,5	25	38	18	4,7	M10	3/8"	71	52,4	53	26,2
278	C. 104-ST-F-F	1" 1/4	42,8	31	41	21	6	M10	7/16"	80	58,7	69	30,2
210	C. 106-ST-F-F	1" 1/2	48,6	38	44	25	5,3	M12	1/2"	94	69,85	77	35,7
210	C. 108-ST-F-F	2"	61	50	45	25	5,5	M12	1/2"	103	77,8	89	42,9
175	C. 110-ST-F-F	2" 1/2	76,6	63	50	25	6,8	M12	1/2"	115	89	101	50,8
138	C. 112-ST-F-F	3"	89	73	50	27	8	M16	5/8"	135	106,4	124	62
35	C. 114-ST-F-F	3" 1/2	103	89	50	27	7	M16	5/8"	153	120,7	137	70
35	C. 116-ST-F-F	4"	115	99	50	27	8	M16	5/8"	163	130	147	77,8
35	C. 118-ST-F-F	5"	141	120	50	28	10,5	M16	5/8"	184	152,4	180	92

serie 6000 psi

Pressione max esercizio bar	Tipo Type	S.A.E.	A	B	C	D	S	G		H	I	L	M
								Metr.	UNC				
420	C. 401-ST-F-F	3/8"	17,5	10	36	16	3,7	M 8	5/16"	57	40,5	47	18,3
420	C. 401-ST-F-F	1/2"	21,6	13	36	16	4,3	M 8	5/16"	57	40,5	47	18,3
420	C. 402-ST-F-F	3/4"	27,2	18	36	19	4,6	M10	3/8"	71	50,8	53	23,8
420	C. 403-ST-F-F	1"	34,5	22	44	24	6,3	M12	7/16"	80	57,1	66	27,8
420	C. 404-ST-F-F	1" 1/4	42,8	28	44	27	7,4	M14	1/2"	94	66,7	77	31,6
420	C. 405-ST-F-F	1" 1/2	48,6	32	51	30	8,3	M16	5/8"	106	79,4	89	36,5
420	C. 406-ST-F-F	2"	61	41	70	37	10	M20	3/4"	135	96,8	116	44,4
420	C. 408-ST-F-F	2" 1/2	76,6	50	75	45	13	M24	-	166	123,8	150	58,7
420	C. 410-ST-F-F	3"	90	58	90	55	16	M30	-	208	152,4	178	71,4

Per ordinazione flange: / Ordering Examples: / Pour commander brides: / Bestellbeispiel für Flansche:

Controflangia con fori fissaggio filettati metrici M-C...ST-F-F
 Counter flange with metric tapholes M-C...ST-F-F
 Contre bride avec trous taraudés metriques M-C...ST-F-F
 Gegenflansch mit Metrischen Gewindebohrungen M-C...ST-F-F

Controflangia con fori fissaggio filettati UNC U-C...ST-F-F
 Counter flange with UNC tapholes U-C...ST-F-F
 Contre bride avec trous taraudés UNC U-C...ST-F-F
 Gegenflansch mit UNC Gewindebohrungen U-C...ST-F-F

Indicare quota "S" dimension
 Specify "S" dimension
 Indiquer quote "S"
 Bestimmen "S" Abmessung

DOPPIA FLANGIA FILETTATA GAS

Double flanges BSP threaded Double bride taraudée BSP Doppelflanschverbinder mit Gewinde

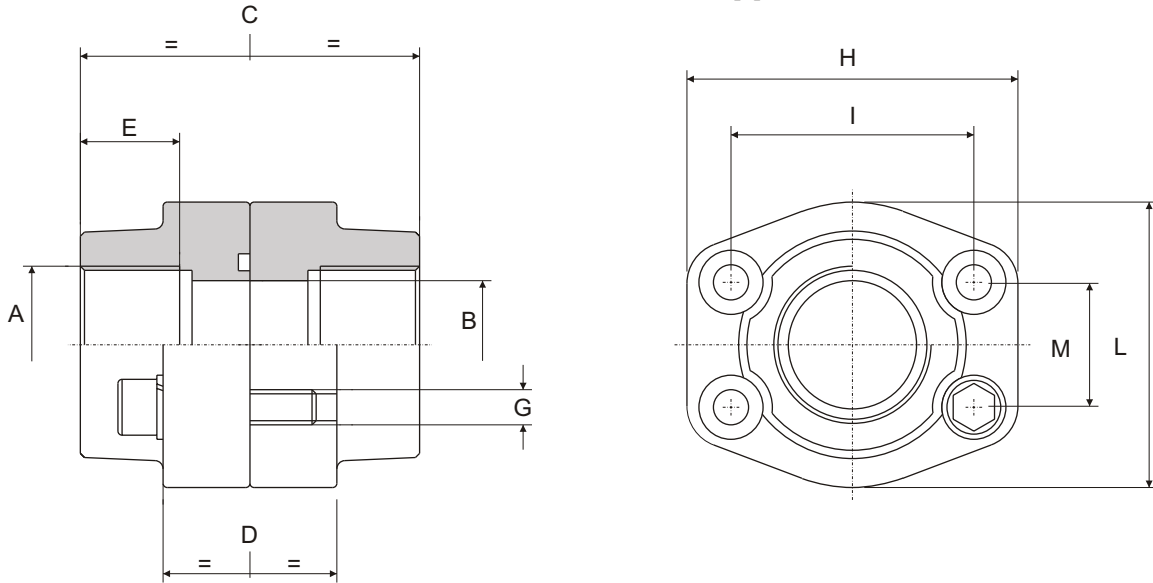

serie 3000 psi

Pressione max esercizio bar	Tipo Type	A S.A.E.	B	C	D	E	G Viti / Bolts		H	I	L	M	OR O-RING
							Metr.	UNC					
348	D.F.S. 080-GAS	3/8"	13	72	32	19	M 8	5/16"	57	38	47	17,5	4075
348	D.F.S. 080-GAS	1/2"	13	72	32	19	M 8	5/16"	57	38	47	17,5	4075
348	D.F.S. 100-GAS	3/4"	19	72	36	19	M10	3/8"	66	47,6	49	22,2	4100
348	D.F.S. 102-GAS	1"	25	76	36	19	M10	3/8"	71	52,4	53	26,2	4131
278	D.F.S. 104-GAS	1" 1/4	31	82	42	22	M10	7/16"	80	58,7	69	30,2	4150
210	D.F.S. 106-GAS	1" 1/2	38	88	48	24	M12	1/2"	94	69,85	77	35,7	4187
210	D.F.S. 108-GAS	2"	50	90	48	26	M12	1/2"	103	77,8	89	42,9	4225
175	D.F.S. 110-GAS	2" 1/2	63	100	48	30	M12	1/2"	115	89	101	50,8	4275
138	D.F.S. 112-GAS	3"	73	100	53	34	M16	5/8"	135	106,4	124	62	4337
35	D.F.S. 114-GAS	3" 1/2	89	100	54	27	M16	5/8"	152	120,7	136	70	4387
35	D.F.S. 116-GAS	4"	99	100	54	30	M16	5/8"	162	130	146	77,8	4437
35	D.F.S. 118-GAS	5"	120	100	54	30	M16	5/8"	184	152,4	180	92	4537

serie 6000 psi

Pressione max esercizio bar	Tipo Type	A S.A.E.	B	C	D	E	G Viti / Bolts		H	I	L	M	OR O-RING
							Metr.	UNC					
420	D.F.S. 401-GAS	3/8"	13	72	32	19	M 8	5/16"	57	40,5	47	18,3	4075
420	D.F.S. 401-GAS	1/2"	13	72	32	19	M 8	5/16"	57	40,5	47	18,3	4075
420	D.F.S. 402-GAS	3/4"	19	72	38	22	M10	3/8"	71	50,8	53	23,8	4100
420	D.F.S. 403-GAS	1"	25	88	48	24	M12	7/16"	80	57,1	69	27,8	4131
420	D.F.S. 404-GAS	1" 1/4	31	88	54	25	M14	1/2"	94	66,7	77	31,6	4150
420	D.F.S. 405-GAS	1" 1/2	38	102	60	28	M16	5/8"	106	79,4	89	36,5	4187
420	D.F.S. 406-GAS	2"	50	140	74	33	M20	3/4"	135	96,8	116	44,4	4225
420	D.F.S. 408-GAS	2" 1/2	63	150	90	35	M24	-	166	123,8	150	58,7	4275
420	D.F.S. 410-GAS	3"	73	180	110	40	M30	-	208	152,4	178	71,4	4337

Per ordinazione flange: / Ordering Examples: / Pour commander brides: / Bestellbeispiel für Flansche:

Doppia flangia completa di viti metriche, rondelle e ORDFS...G-M
 Complete double flange with metric screws, washers and o-ringDFS...G-M
 Double bride complete des vis métriques rondelles et ORDFS...G-M
 Doppelflanschverbinder einschl. metrischen Zylinderschrauben, Federringen und O-Ring...DFS...G-M

Doppia flangia completa di viti UNC, rondelle e ORDFS...G-U
 Complete double flange with UNC screws, washers and o-ringDFS...G-U
 Double bride complete des vis UNC, rondelles et ORDFS...G-U
 Doppelflanschverbinder einschl. UNC-Schrauben, Federringen und O-Ring...DFS...G-U

DOPPIA FLANGIA A SALDARE DI TASCA

— Double flanges socket weld
 Double bride à emmanchement
 Doppelflanschverbinder zum Einlöten

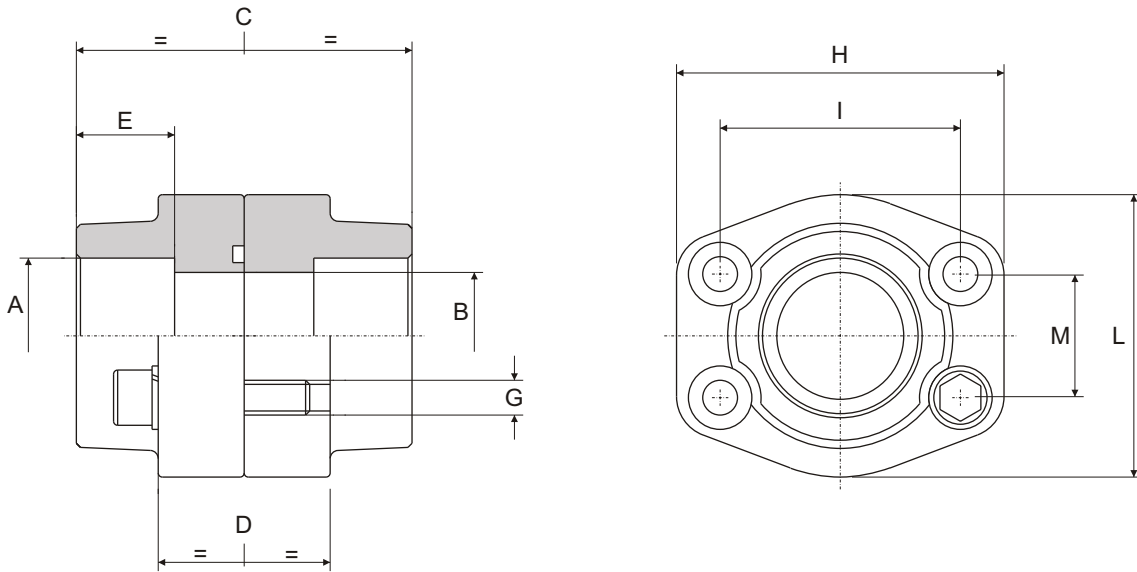

serie 3000 psi

Pressione max esercizio bar	Tipo Type	S.A.E.	A	B	C	D	E	G Viti / Bolts		H	I	L	M	OR O-RING
								Metr.	UNC					
348	D.F.S. 080-S	3/8"	17,5	13	72	36	18	M 8	5/16"	57	38	47	17,5	4075
348	D.F.S. 080-S	1/2"	21,6	13	72	36	18	M 8	5/16"	57	38	47	17,5	4075
348	D.F.S. 100-S	3/4"	27,2	19	72	36	18	M10	3/8"	66	47,6	49	22,2	4100
348	D.F.S. 102-S	1"	34,1	25	76	36	18	M10	3/8"	71	52,4	53	26,2	4131
278	D.F.S. 104-S	1" 1/4	42,8	31	82	42	20	M10	7/16"	80	58,7	69	30,2	4150
210	D.F.S. 106-S	1" 1/2	48,6	38	88	48	22	M12	1/2"	94	69,85	77	35,7	4187
210	D.F.S. 108-S	2"	61	50	90	48	24	M12	1/2"	103	77,8	89	42,9	4225
175	D.F.S. 110-S	2" 1/2	76,6	63	100	48	28	M12	1/2"	116	89	101	50,8	4275
138	D.F.S. 112-S	3"	90,5	73	100	53	28	M16	5/8"	135	106,4	124	62	4337
35	D.F.S. 114-S	3" 1/2	103	89	100	54	28	M16	5/8"	153	120,7	137	70	4387
35	D.F.S. 116-S	4"	115,5	99	100	54	28	M16	5/8"	163	130	147	77,8	4437
35	D.F.S. 118-S	5"	142	120	100	54	28	M16	5/8"	184	152,4	180	92	4537

serie 6000 psi

Pressione max esercizio bar	Tipo Type	S.A.E.	A	B	C	D	E	G Viti / Bolts		H	I	L	M	OR O-RING
								Metr.	UNC					
420	D.F.S. 401-S	3/8"	17,5	13	72	32	18	M 8	5/16"	57	40,5	47	18,3	4075
420	D.F.S. 401-S	1/2"	21,6	13	72	32	18	M 8	5/16"	57	40,5	47	18,3	4075
420	D.F.S. 402-S	3/4"	27,2	19	72	38	20	M10	3/8"	71	50,8	53	23,8	4100
420	D.F.S. 403-S	1"	34,1	25	88	48	22	M12	7/16"	80	57,1	66	27,8	4131
420	D.F.S. 404-S	1" 1/4	42,8	31	88	54	22	M14	1/2"	94	66,7	77	31,6	4150
420	D.F.S. 405-S	1" 1/2	48,6	38	102	60	24	M16	5/8"	106	79,4	89	36,5	4187
420	D.F.S. 406-S	2"	61	50	140	74	25	M20	3/4"	135	96,8	116	44,4	4225
420	D.F.S. 408-S	2" 1/2	76,6	63	150	90	28	M24	-	166	123,8	150	58,7	4275
420	D.F.S. 410-S	3"	90,5	73	180	110	30	M30	-	208	152,4	178	71,4	4337

Per ordinazione flange: / Ordering Examples: / Pour commander brides: / Bestellbeispiel für Flansche:

Doppia flangia completa di viti metriche, rondelle e OR DFS...S-M
 Complete double flange with metrical screws, washers and o-ring DFS...S-M
 Double bride complete des vis métriques rondelles et OR DFS...S-M
 Doppelflanschverbinder einschl. metrischen Zylinderschrauben, Federringen und O-Ring... DFS...S-M

Doppia flangia completa di viti UNC, rondelle e OR DFS...S-U
 Complete double flange with UNC screws, washers and o-ring DFS...S-U
 Double bride complete des vis UNC, rondelles et OR DFS...S-U
 Doppelflanschverbinder einschl. UNC-Schrauben, Federringen und O-Ring... DFS...S-U

DOPPIA FLANGIA A SALDARE DI TESTA

Double flanges butt weld
Double bride bout à bout
Doppelflanschverbinder zum Anschweißen

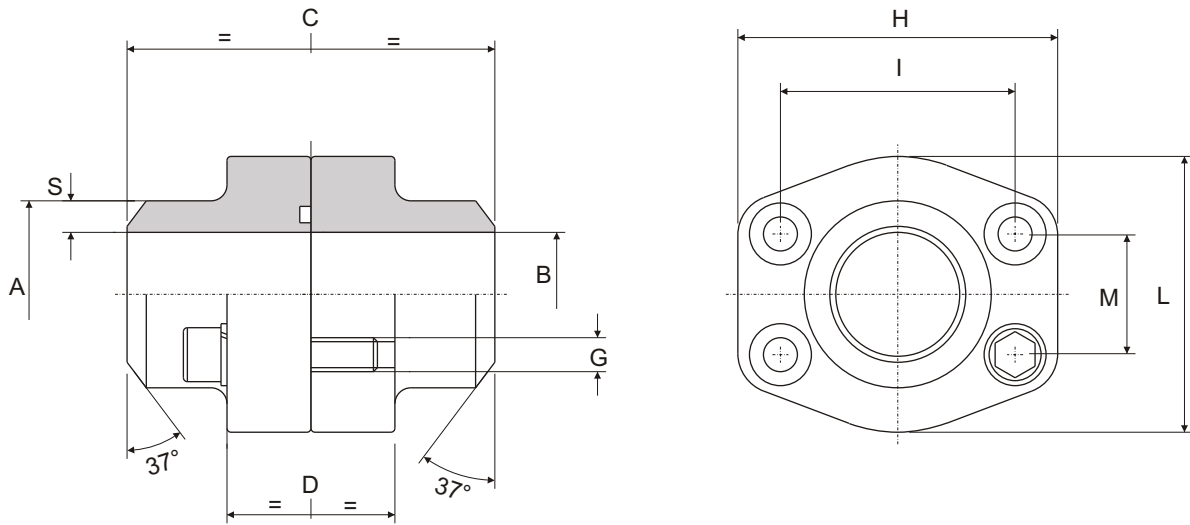

serie 3000 psi

Pressione max esercizio bar	Tipo Type	S.A.E.	A	B	C	D	S	G Viti / Bolts		H	I	L	M	OR O-RING
								Metr.	UNC					
348	D.F.S. 080-ST	1/2"	21,6	13	72	32	4,3	M 8	5/16"	57	38	47	17,5	4075
348	D.F.S. 100-ST	3/4"	27,2	19	72	36	4,1	M10	3/8"	66	47,6	49	22,2	4100
348	D.F.S. 102-ST	1"	34,5	25	76	36	4,7	M10	3/8"	71	52,4	53	26,2	4131
278	D.F.S. 104-ST	1" 1/4	42,8	31	82	42	6	M10	7/16"	80	58,7	69	30,2	4150
210	D.F.S. 106-ST	1" 1/2	48,6	38	88	48	5,3	M12	1/2"	94	69,85	77	35,7	4187
210	D.F.S. 108-ST	2"	61	50	90	48	5,5	M12	1/2"	103	77,8	89	42,9	4225
175	D.F.S. 110-ST	2" 1/2	76,6	63	100	48	6,8	M12	1/2"	115	89	101	50,8	4275
138	D.F.S. 112-ST	3"	89	73	100	53	8	M16	5/8"	135	106,4	124	62	4337
35	D.F.S. 114-ST	3" 1/2	103	89	100	54	7	M16	5/8"	153	120,7	137	70	4387
35	D.F.S. 116-ST	4"	115	99	100	54	8	M16	5/8"	163	130	147	77,8	4337
35	D.F.S. 118-ST	5"	141	120	100	54	10,5	M16	5/8"	184	152,4	180	92	4537

serie 6000 psi

Pressione max esercizio bar	Tipo Type	S.A.E.	A	B	C	D	S	G Viti / Bolts		H	I	L	M	OR O-RING
								Metr.	UNC					
420	D.F.S. 401-ST	3/8"	17,5	10	72	32	3,7	M 8	5/16"	57	40,5	47	18,3	4075
420	D.F.S. 401-ST	1/2"	21,6	13	72	32	4,3	M 8	5/16"	57	40,5	47	18,3	4075
420	D.F.S. 402-ST	3/4"	27,2	18	72	38	4,6	M10	3/8"	71	50,8	53	23,8	4100
420	D.F.S. 403-ST	1"	34,5	22	88	48	6,3	M12	7/16"	80	57,1	66	27,8	4131
420	D.F.S. 404-ST	1" 1/4	42,8	28	88	54	7,4	M14	1/2"	94	66,7	77	31,6	4150
420	D.F.S. 405-ST	1" 1/2	48,6	32	102	60	8,3	M16	5/8"	106	79,4	89	36,5	4187
420	D.F.S. 406-ST	2"	61	41	140	74	10	M20	3/4"	135	96,8	116	44,4	4225
420	D.F.S. 408-ST	2" 1/2	76,6	50	150	90	13	M24	-	166	123,8	150	58,7	4275
420	D.F.S. 410-ST	3"	90	58	180	110	16	M30	-	208	152,4	178	71,4	4337

Per ordinazione flange: / Ordering Examples: / Pour commander brides: / Bestellbeispiel für Flansche:

Doppia flangia completa di viti metriche, rondelle e ORDFS...ST-M
Complete double flange with metrical screws, washers and o-ringDFS...ST-M
Double bride complete des vis métriques rondelles et ORDFS...ST-M
Doppelflanschverbinder einschl. metrischen Zylinderschrauben, Federringen und O-Ring...DFS...ST-M

Doppia flangia completa di viti UNC, rondelle e ORDFS...ST-U
Complete double flange with UNC screws, washers and o-ringDFS...ST-U
Double bride complete des vis UNC, rondelles et ORDFS...ST-U
Doppelflanschverbinder einschl. UNC-Schrauben, Federringen und O-Ring...DFS...ST-U

FLANGIA CIECA

Closed flanges
Bride d'obturation
Verschlußflansch

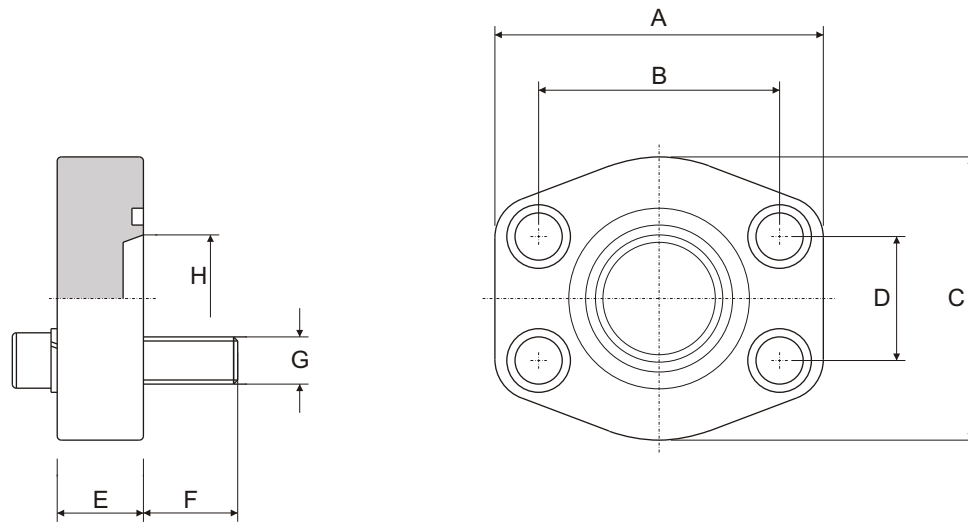

serie 3000 psi

Pressione max esercizio bar	Tipo Type	S.A.E.	A	B	C	D	E	F	G Viti / Bolts		H	OR O-RING
									Metr.	UNC		
348	C.F.C.S. 080	1/2"	57	38	47	17,5	16	14	M 8	5/16"	10	4075
348	C.F.C.S. 100	3/4"	66	47,6	49	22,2	18	16	M10	3/8"	15	4100
348	C.F.C.S. 102	1"	71	52,4	53	26,2	19	16	M10	3/8"	18	4131
278	C.F.C.S. 104	1" 1/4	80	58,7	69	30,2	21	18	M10	7/16"	23	4150
210	C.F.C.S. 106	1" 1/2	95	69,85	77	35,7	24	19	M12	1/2"	28	4187
210	C.F.C.S. 108	2"	103	77,8	89	42,9	24	19	M12	1/2"	45	4225
175	C.F.C.S. 110	2" 1/2	116	89	101	50,8	25	19	M12	1/2"	58	4275
138	C.F.C.S. 112	3"	136	106,4	124	62	25	27	M16	5/8"	70	4337
35	C.F.C.S. 114	3" 1/2	152	120,7	136	70	25	27	M16	5/8"	85	4387
35	C.F.C.S. 116	4"	162	130	146	77,8	25	27	M16	5/8"	95	4437
35	C.F.C.S. 118	5"	184	152,4	180	92	25	27	M16	5/8"	110	4537

serie 6000 psi

Pressione max esercizio bar	Tipo Type	S.A.E.	A	B	C	D	E	F	G Viti / Bolts		H	OR O-RING
									Metr.	UNC		
420	C.F.C.S. 401	3/8"	57	40,5	47	18,3	16	14	M 8	5/16"	10	4075
420	C.F.C.S. 402	3/4"	71	50,8	53	23,8	19	16	M10	3/8"	15	4100
420	C.F.C.S. 403	1"	80	57,1	66	27,8	24	18	M12	7/16"	22	4131
420	C.F.C.S. 404	1" 1/4	94	66,7	77	31,6	27	24	M14	1/2"	30	4150
420	C.F.C.S. 405	1" 1/2	103	79,4	89	36,5	30	24	M16	5/8"	35	4187
420	C.F.C.S. 406	2"	135	96,8	123	44,4	35	31	M20	3/4"	48	4225
420	C.F.C.S. 408	2" 1/2	166	123,8	150	58,7	45	40	M24	-	55	4275
420	C.F.C.S. 410	3"	208	152,4	178	71,4	55	45	M30	-	65	4337

Per ordinazione flange: / Ordering Examples: / Pour commander brides: / Bestellbeispiel für Flansche:

Solo flangia..... CFCS...-	Flangia completa di viti UNC, rondelle e OR..... CFCS...U	Flangia completa di viti metriche, rondelle e OR..... CFCS...M
Only flange..... CFCS...-	Complete flange with UNC screws, washers and o-ring..... CFCS...U	Complete flange with metrical screws, washers and o-ring..... CFCS...M
Seulement bride... CFCS...-	Bride complete des vis UNC, rondelles et OR..... CFCS...U	Bride complete des vis métriques, rondelles et OR..... CFCS...M
Nur Flansch..... CFCS...-	Flansch einschl. UNC-Schrauben, Federringen und O-Ring... CFCS...U	Flansch einschl. metrischen Zylinderschrauben, Federringen und O-Ring... CFCS...M

FLANGIA PIATTA A SALDARE

Socket welding flat flange
Bride plat à emmanchement
Einschweissflanschflache Bauform

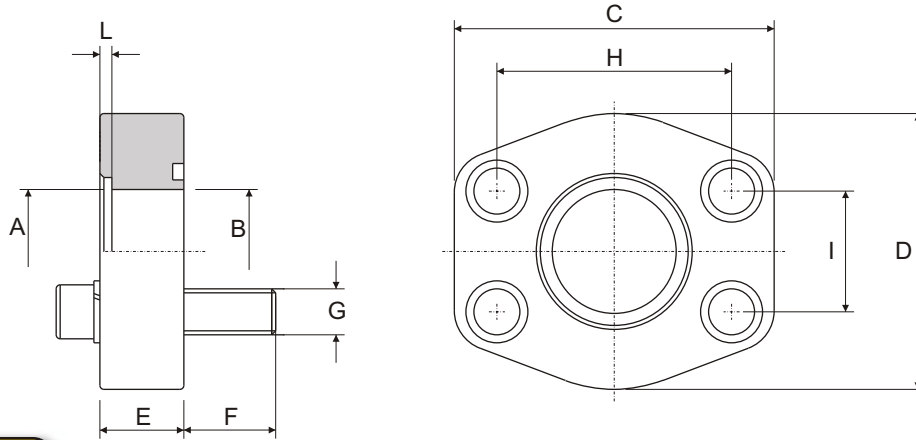

serie 3000 psi

Tipo Type	A	B	S.A.E.	C	D	E	F	G Viti / Bolts		H	I	L	OR O-RING
								Metr.	UNC				
F.P.S. 080-S	17,5 21,6	13	1/2"	57	47	16	14	M 8	5/16"	38	17,5	3	4075
F.P.S. 100-S	21,6 27,2	13 19	3/4"	66	49	18	16	M10	3/8"	47,6	22,2	4	4100
F.P.S. 102-S	27,2 34,5	19 25	1"	71	53	19	16	M10	3/8"	52,4	26,2	4	4131
F.P.S. 104-S	34,5 42,8	25 31	1" 1/4	80	69	21	18	M10	7/16"	58,7	30,2	4	4150
F.P.S. 106-S	42,8 48,6	31 38	1" 1/2	95	77	24	19	M12	1/2"	69,85	35,7	4	4187
F.P.S. 108-S	48,6 61	38 50	2"	103	89	24	19	M12	1/2"	77,8	42,9	4	4225
F.P.S. 110-S	61 76,6	50 63	2" 1/2	116	101	25	19	M12	1/2"	89	50,8	5	4275
F.P.S. 112-S	76,6 90,5	63 73	3"	136	124	25	27	M16	5/8"	106,4	62	5	4337
F.P.S. 114-S	90,5 103	73 89	3" 1/2	152	136	25	27	M16	5/8"	120,7	70	5	4387
F.P.S. 116-S	103 115,5	89 99	4"	162	146	25	27	M16	5/8"	130	77,8	6	4437
F.P.S. 118-S	115,5 142,5	99 120	5"	184	180	25	27	M16	5/8"	152,4	92	6	4537

serie 6000 psi

Tipo Type	A	B	S.A.E.	C	D	E	F	G Viti / Bolts		H	I	L	OR O-RING
								Metr.	UNC				
F.P.S. 401-S	17,5 21,6	13	1/2"	57	47	16	14	M 8	5/16"	40,5	18,3	4	4075
F.P.S. 402-S	21,6 27,2	13 19	3/4"	71	53	19	16	M10	3/8"	50,8	23,8	4	4100
F.P.S. 403-S	27,2 34,5	19 25	1"	80	66	24	18	M12	7/16"	57,1	27,8	4	4131
F.P.S. 404-S	34,5 42,8	25 31	1" 1/4	94	77	27	24	M14	1/2"	66,7	31,6	4	4150
F.P.S. 405-S	42,8 48,6	31 38	1" 1/2	103	89	30	24	M16	5/8"	79,4	36,5	4	4187
F.P.S. 406-S	48,6 61	38 50	2"	135	123	35	31	M20	3/4"	96,8	44,4	4	4225

Per ordinazione flange: / Ordering Examples: / Pour commander brides: / Bestellbeispiel für Flansche:

Solo flangia..... F.P.S...
 Only flange..... F.P.S...
 Seulement bride... F.P.S...
 Nur Flansch..... F.P.S...
 Flangia completa di viti UNC, rondelle e OR..... F.P.S...U
 Complete flange with UNC screws, washers and o-ring..... F.P.S...U
 Bride complete des vis UNC, rondelles et OR..... F.P.S...U
 Flansch einschl. UNC-Schrauben, Federringen und O-Ring... F.P.S...U
 Flangia completa di viti metriche, rondelle e OR..... F.P.S...M
 Complete flange with metrical screws, washers and o-ring..... F.P.S...M
 Bride complete des vis métriques, rondelles et OR..... F.P.S...M
 Flansch einschl. metrischen Zylinderschrauben, Federringen und O-Ring.. F.P.S...M

FLANGIA PIATTA FILETTATA

Threaded flat flange
Bride plat taraudée
Gewindeflanschfläche Bauform

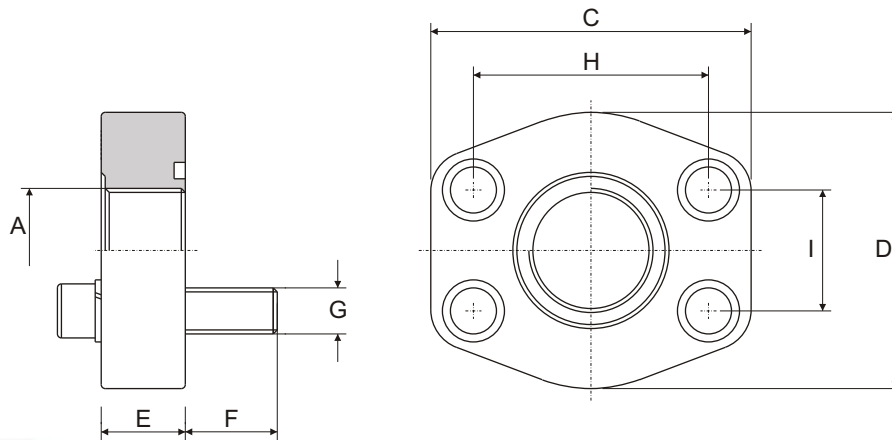

serie 3000 psi

Tipo Type	A S.A.E.	C	D	E	F	G Viti / Bolts		H	I	OR O-RING
						Metr.	UNC			
F.P.G. 080-G	3/8" 1/2"	57	47	16	14	M 8	5/16"	38	17,5	4075 3100
F.P.G. 100-G	1/2" 3/4"	66	49	18	16	M10	3/8"	47,6	22,2	4100 4125
F.P.G. 102-G	3/4" 1"	71	53	19	16	M10	3/8"	52,4	26,2	4131 4150
F.P.G. 104-G	1" 1 1/4"	80	69	21	18	M10	7/16"	58,7	30,2	4150 149
F.P.G. 106-G	1 1/4" 1 1/2"	95	77	24	19	M12	1/2"	69,85	35,7	4187 156
F.P.G. 108-G	1 1/2" 2"	103	89	24	19	M12	1/2"	77,8	42,9	4225 168
F.P.G. 110-G	2" 2 1/2"	116	101	25	19	M12	1/2"	89	50,8	4275 4312
F.P.G. 112-G	2 1/2" 3"	136	124	25	27	M16	5/8"	106,4	62	4337 4375
F.P.G. 114-G	3" 3 1/2"	152	136	25	27	M16	5/8"	120,7	70	4387 4425
F.P.G. 116-G	3 1/2" 4"	162	146	25	27	M16	5/8"	130	77,8	4437 4462
F.P.G. 118-G	4" 5"	184	180	25	27	M16	5/8"	152,4	92	4537 4575

serie 6000 psi

Tipo Type	A S.A.E.	C	D	E	F	G Viti / Bolts		H	I	OR O-RING
						Metr.	UNC			
F.P.G. 401-G	3/8" 1/2"	57	47	16	14	M 8	5/16"	40,5	18,3	4075 3100
F.P.G. 402-G	1/2" 3/4"	71	53	19	16	M10	3/8"	50,8	23,8	4100 4131
F.P.G. 403-G	3/4" 1"	80	66	24	18	M12	7/16"	57,1	27,8	4131 4150
F.P.G. 404-G	1" 1 1/4"	94	77	27	24	M14	1/2"	66,7	31,6	4150 149
F.P.G. 405-G	1 1/4" 1 1/2"	103	89	30	24	M16	5/8"	79,4	36,5	4187 156
F.P.G. 406-G	1 1/2" 2"	135	123	35	31	M20	3/4"	96,8	44,4	4225 168

Per ordinazione flange: / Ordering Examples: / Pour commander brides: / Bestellbeispiel für Flansche:

Solo flangia..... FPG...-
 Only flange..... FPG...-
 Seulement bride... FPG...-
 Nur Flansch..... FPG...-

Flangia completa di viti UNC, rondelle e OR..... FPG...U
 Complete flange with UNC screws, washers and o-ring..... FPG...U
 Bride complete des vis UNC, rondelles et OR..... FPG...U
 Flansch einschl. UNC-Schrauben, Federringen und O-Ring... FPG...U

Flangia completa di viti metriche, rondelle e OR..... FPG...M
 Complete flange with metrical screws, washers and o-ring..... FPG...M
 Bride complete des vis métriques, rondelles et OR..... FPG...M
 Flansch einschl. metrischen Zylinderschrauben, Federringen und O-Ring... FPG...M

FLANGIA DI CHIUSURA / PROTEZIONE

Locking / protection Flange
Bride de fermeture / protection
Abschlußplatte

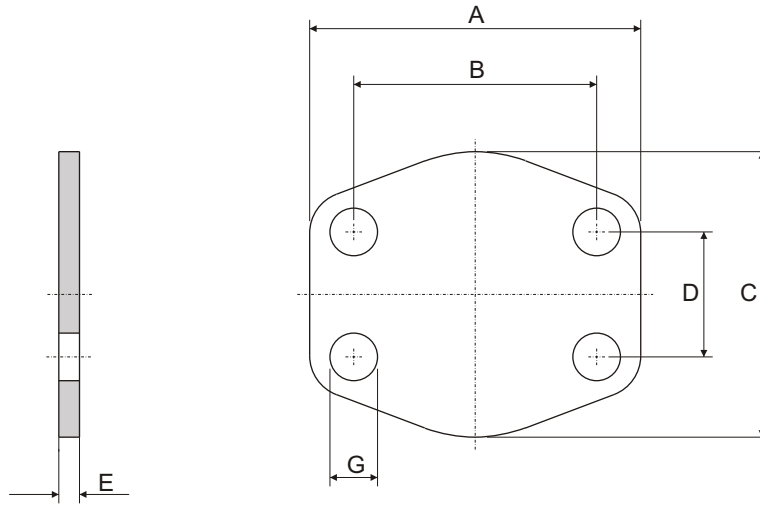

serie 3000 psi

Tipo Type	S.A.E.	A	B	C	D	E	G
CP 080	1/2"	57	38	47	17,5	3	9
CP 100	3/4"	66	47,6	49	22,2	3	11
CP 102	1"	71	52,4	53	26,2	3	11
CP 104	1" 1/4	80	58,7	69	30,2	3	11,5
CP 106	1" 1/2	95	69,85	77	35,7	3	13,5
CP 108	2"	103	77,8	89	42,9	3	13,5
CP 110	2" 1/2	116	89	101	50,8	3	13,5
CP 112	3"	136	106,4	124	62	4	17
CP 114	3" 1/2	152	120,7	136	70	4	17
CP 116	4"	162	130	146	77,8	4	17
CP 118	5"	184	152,4	180	92	4	17

serie 6000 psi

Tipo Type	S.A.E.	A	B	C	D	E	G
CP 401	1/2"	57	40,5	47	18,3	4	9
CP 402	3/4"	71	50,8	53	23,8	4	11
CP 403	1"	80	57,1	66	27,8	4	13
CP 404	1" 1/4	94	66,7	77	31,6	4	15
CP 405	1" 1/2	103	79,4	89	36,5	4	17
CP 406	2"	135	96,8	123	44,4	4	21
CP 408	2" 1/2	166	123,8	150	58,7	4	25
CP 410	3"	208	152,4	178	71,4	4	32

Per ordinazione flange: / Ordering Examples: / Pour commander brides: / Bestellbeispiel für Flansche:

Solo flangia.....CP..
Only flange.....CP..
Seulement bride...CP..
Nur Flansch.....CP..

Flangia zincataCP..ZG
Zinc Plated FlangeCP..ZG
Bride zinguée.....CP..ZG
Verzinkt FlanschCP..ZG

FLANGIA DI CONNESSIONE

**Connector Flange
Bride de liaison
Zwischenplatte**

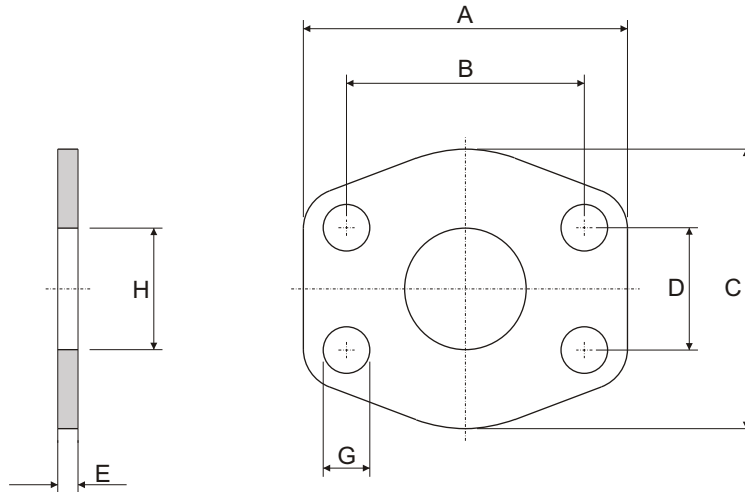

serie 3000 psi

Tipo Type	S.A.E.	A	B	C	D	E	G	H
FP 080	1/2"	57	38	47	17,5	3	9	13
FP 100	3/4"	66	47,6	49	22,2	3	11	19
FP 102	1"	71	52,4	53	26,2	3	11	25
FP 104	1" 1/4	80	58,7	69	30,2	3	11,5	32
FP 106	1" 1/2	95	69,85	77	35,7	3	13,5	38
FP 108	2"	103	77,8	89	42,9	3	13,5	51
FP 110	2" 1/2	116	89	101	50,8	3	13,5	63
FP 112	3"	136	106,4	124	62	4	17	73
FP 114	3" 1/2	152	120,7	136	70	4	17	89
FP 116	4"	162	130	146	77,8	4	17	99
FP 118	5"	184	152,4	180	92	4	17	120

serie 6000 psi

Tipo Type	S.A.E.	A	B	C	D	E	G	H
FP 401	1/2"	57	40,5	47	18,3	4	9	13
FP 402	3/4"	71	50,8	53	23,8	4	11	17
FP 403	1"	80	57,1	66	27,8	4	13	24
FP 404	1" 1/4	94	66,7	77	31,6	4	15	31
FP 405	1" 1/2	103	79,4	89	36,5	4	17	38
FP 406	2"	135	96,8	123	44,4	4	21	51
FP 408	2" 1/2	166	123,8	150	58,7	4	25	63
FP 410	3"	208	152,4	178	71,4	4	32	73

Per ordinazione flange: / Ordering Examples: / Pour commander brides: / Bestellbeispiel für Flansche:

Solo flangia.....CP..
Only flange.....CP..
Seulement bride...CP..
Nur Flansch.....CP..

Flangia zincataCP..ZG
Zinc Plated FlangeCP..ZG
Bride zinguée.....CP..ZG
Verzinkt Flansche.....CP..ZG

FLANGIA A 90° FILETTATA GAS

90° Flanges with BSP thread
Bride à 90° taraudée BSP
90° Flanschverbinder mit Gewinde

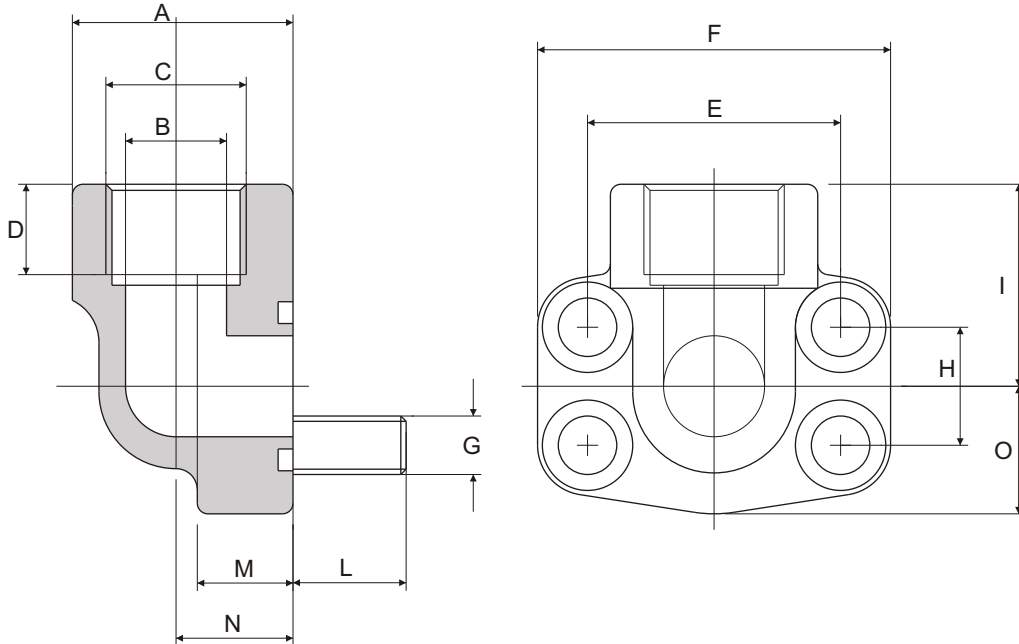

serie 3000 psi

Pressione max esercizio bar	Tipo Type	C S.A.E.	A	B	D	E	F	G Viti / Bolts		H	I	O	M	N	L	OR O-RING
								Metr.	UNC							
348	F.S.280.90°-GAS	1/2"	34	13	19	38	57	M 8	5/16"	17,5	36	23	17	18	13	4075
348	F.S.300.90°-GAS	3/4"	38,5	19	19	47,6	68	M10	3/8"	22,2	38	25	18	22	15	4100
348	F.S.302.90°-GAS	1"	44,5	25	19	52,4	74	M10	3/8"	26,2	41	27	19	28	15	4131
278	F.S.304.90°-GAS	1" 1/4	53,5	31	22	58,7	81	M10	7/16"	30,2	50	34	22	30	17	4150
210	F.S.306.90°-GAS	1" 1/2	62,5	38	24	69,85	95	M12	1/2"	35,7	58	39	25	36	18	4187
210	F.S.308.90°-GAS	2"	77	50	26	77,8	105	M12	1/2"	42,9	65	44	25	41	18	4225
175	F.S.310.90°-GAS	2" 1/2	89	60	30	88,9	115	M12	1/2"	50,8	77	50	25	50	18	4275

serie 6000 psi

Pressione max esercizio bar	Tipo Type	C S.A.E.	A	B	D	E	F	G Viti / Bolts		H	I	O	M	N	L	OR O-RING
								Metr.	UNC							
420	F.S.580.90°-GAS	1/2"	34	13	19	40,5	57	M 8	5/16"	18,3	36	23	17	18	13	4075
420	F.S.600.90°-GAS	3/4"	44,5	19	22	50,8	72	M10	3/8"	23,8	41	27	20	28	15	4100
420	F.S.602.90°-GAS	1"	53,5	25	24	57,1	82	M12	7/16"	27,8	50	34	24	30	19	4131
420	F.S.604.90°-GAS	1" 1/4	62,5	31	25	66,7	95	M14	1/2"	31,6	58	39	25	36	21	4150
420	F.S.606.90°-GAS	1" 1/2	77	38	28	79,4	110	M16	5/8"	36,5	65	44	26	41	25	4187
420	F.S.608.90°-GAS	2"	87	50	34	96,8	134	M20	3/4"	44,4	75	58	35	45	32	4225

Per ordinazione flange: / Ordering Examples: / Pour commander brides: / Bestellbeispiel für Flansche:

Solo flangia..... FS...G	Flangia completa di viti UNC, rondelle e OR..... FS...G-U	Flangia completa di viti metriche, rondelle e OR..... FS...G-M
Only flange..... FS...G	Complete flange with UNC screws, washers and o-ring..... FS...G-U	Complete flange with metrical screws, washers and o-ring..... FS...G-M
Seulement bride... FS...G	Bride complete des vis UNC, rondelles et OR..... FS...G-U	Bride complete des vis métriques, rondelles et OR..... FS...G-M
Nur Flansch..... FS...G	Flansch einschl. UNC-Schrauben, Federringen und O-Ring... FS...G-U	Flansch einschl. metrischen Zylinderschrauben, Federringen und O-Ring... FS...G-M

FLANGIA A 90° FILETTATA NPT

NPT 90° Flanges
Bride à 90° taraudée NPT
90° Einschraubflansch NPT

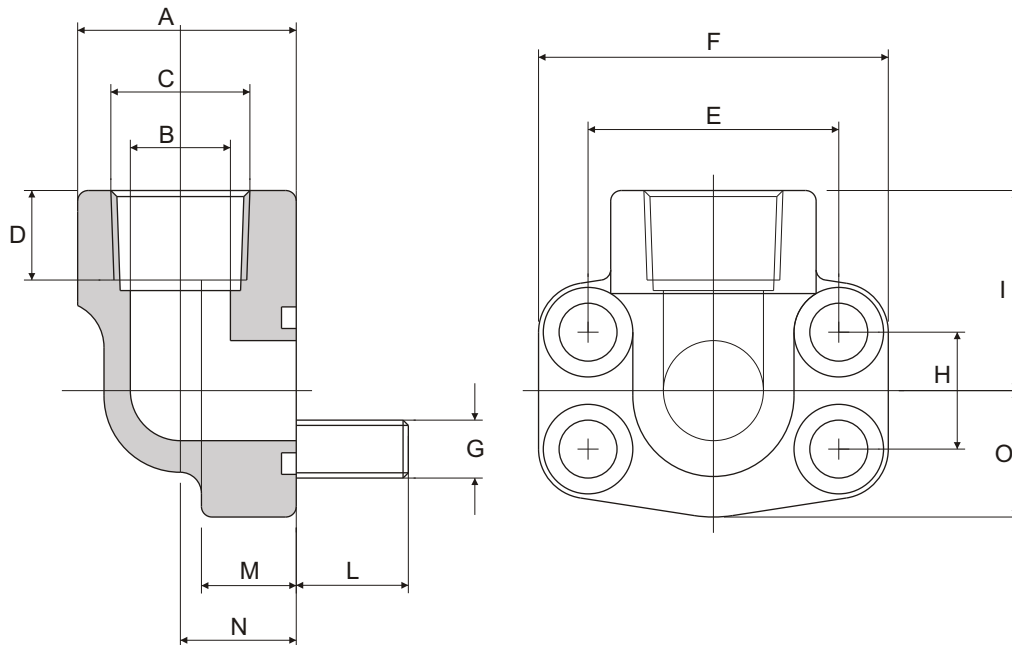

serie 3000 psi

Pressione max esercizio bar	Tipo Type	C S.A.E.	A	B	D	E	F	G Viti / Bolts		H	I	O	M	N	L	OR O-RING
								Metr.	UNC							
348	F.S.280.90°-NPT	1/2"	34	13	19	38	57	M 8	5/16"	17,5	36	23	17	18	13	4075
348	F.S.300.90°-NPT	3/4"	38,5	19	19	47,6	68	M10	3/8"	22,2	38	25	18	22	15	4100
348	F.S.302.90°-NPT	1"	44,5	25	19	52,4	74	M10	3/8"	26,2	41	27	19	28	15	4131
278	F.S.304.90°-NPT	1" 1/4	53,5	31	22	58,7	81	M10	7/16"	30,2	50	34	22	30	17	4150
210	F.S.306.90°-NPT	1" 1/2	62,5	38	24	69,85	95	M12	1/2"	35,7	58	39	25	36	18	4187
210	F.S.308.90°-NPT	2"	77	50	26	77,8	105	M12	1/2"	42,9	65	44	25	41	18	4225
175	F.S.310.90°-NPT	2" 1/2	89	60	30	88,9	115	M12	1/2"	50,8	77	50	25	50	18	4275

serie 6000 psi

Pressione max esercizio bar	Tipo Type	C S.A.E.	A	B	D	E	F	G Viti / Bolts		H	I	O	M	N	L	OR O-RING
								Metr.	UNC							
420	F.S.580.90°-NPT	1/2"	34	13	19	40,5	57	M 8	5/16"	18,3	36	23	17	18	13	4075
420	F.S.600.90°-NPT	3/4"	44,5	19	22	50,8	72	M10	3/8"	23,8	41	27	20	28	15	4100
420	F.S.602.90°-NPT	1"	53,5	25	24	57,1	82	M12	7/16"	27,8	50	34	24	30	19	4131
420	F.S.604.90°-NPT	1" 1/4	62,5	31	25	66,7	95	M14	1/2"	31,6	58	39	25	36	21	4150
420	F.S.606.90°-NPT	1" 1/2	77	38	28	79,4	110	M16	5/8"	36,5	65	44	26	41	25	4187
420	F.S.608.90°-NPT	2"	87	50	34	96,8	134	M20	3/4"	44,4	75	58	35	45	32	4225

Per ordinazione flange: / Ordering Examples: / Pour commander brides: / Bestellbeispiel für Flansche:

Solo flangia..... FS...N
 Only flange..... FS...N
 Seulement bride... FS...N
 Nur Flansch..... FS...N

Flangia completa di viti UNC, rondelle e OR..... FS...N-U
 Complete flange with UNC screws, washers and o-ring..... FS...N-U
 Bride complete des vis UNC, rondelles et OR..... FS...N-U
 Flansch einschl. UNC-Schrauben, Federringen und O-Ring... FS...N-U

Flangia completa di viti metriche, rondelle e OR..... FS...N-M
 Complete flange with metrical screws, washers and o-ring..... FS...N-M
 Bride complete des vis métriques, rondelles et OR..... FS...N-M
 Flansch einschl. metrischen Zylinderschrauben, Federringen und O-Ring... FS...N-M

FLANGIA A 90° A SALDARE DI TASCA

90° Flanges socket weld
Bride à 90° à emmanchement
90° Flanschverbinder zum Einschweißen

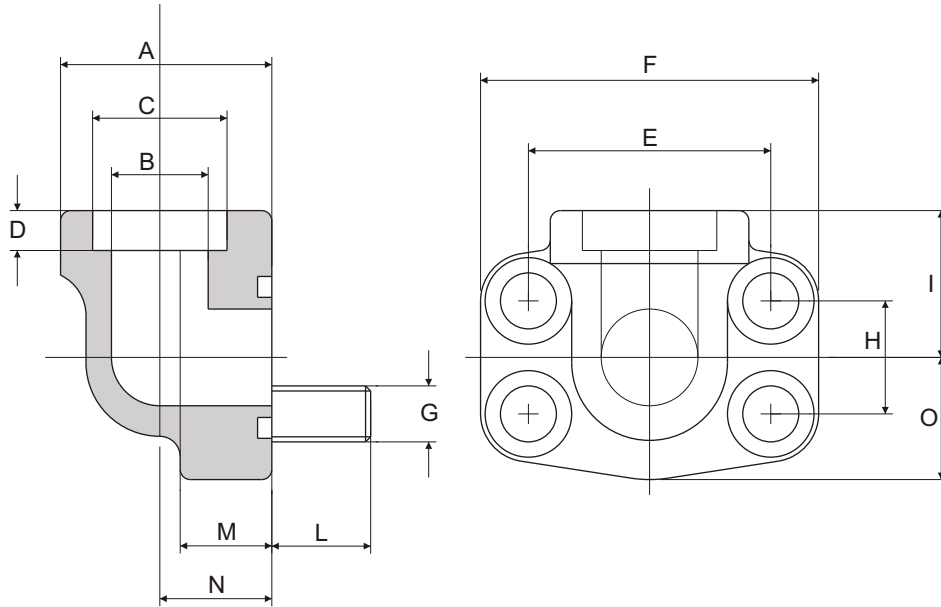

serie 3000 psi

Pressione max esercizio bar	Tipo Type	A	S.A.E.	B	C	D	E	F	G Viti / Bolts		H	I	O	M	N	L	OR O-RING
									Metr.	UNC							
348	F.S.280.90°-S	34	1/2"	13	21,6	5	38	57	M 8	5/16"	17,5	28	23	17	18	13	4075
348	F.S.300.90°-S	38,5	3/4"	19	27,2	5	47,6	68	M10	3/8"	22,2	25	25	18	22	15	4100
348	F.S.302.90°-S	44,5	1"	25	34,1	6	52,4	72	M10	3/8"	26,2	28	27	19	28	15	4131
278	F.S.304.90°-S	53,5	1" 1/4	31	42,8	7	58,7	82	M10	7/16"	30,2	34	34	22	30	17	4150
210	F.S.306.90°-S	62,5	1" 1/2	38	48,6	8	69,85	95	M12	1/2"	35,7	43	39	25	36	18	4187
210	F.S.308.90°-S	77	2"	50	61	10	77,8	105	M12	1/2"	42,9	50	44	25	41	18	4225
175	F.S.310.90°-S	85	2" 1/2	60	76,6	28	88,9	115	M12	1/2"	50,8	77	50	25	50	18	4275

serie 6000 psi

Pressione max esercizio bar	Tipo Type	A	S.A.E.	B	C	D	E	F	G Viti / Bolts		H	I	O	M	N	L	OR O-RING
									Metr.	UNC							
420	F.S.580.90°-S	34	1/2"	13	21,6	5	40,5	57	M 8	5/16"	18,3	28	23	17	18	13	4075
420	F.S.600.90°-S	44,5	3/4"	19	27,2	6	50,8	72	M10	3/8"	23,8	28	27	19	28	15	4100
420	F.S.602.90°-S	53,5	1"	25	34,1	7	57,1	82	M12	7/16"	27,8	34	34	24	30	19	4131
420	F.S.604.90°-S	62,5	1" 1/4	31	42,8	8	66,7	95	M14	1/2"	31,6	43	39	25	36	21	4150
420	F.S.606.90°-S	77	1" 1/2	38	48,6	10	79,4	110	M16	5/8"	36,5	50	44	26	41	25	4187
420	F.S.608.90°-S	89	2"	50	61	12	96,8	134	M20	3/4"	44,4	65	58	35	45	32	4225

Per ordinazione flange: / Ordering Examples: / Pour commander brides: / Bestellbeispiel für Flansche:

Solo flangia..... FS...S
Only flange..... FS...S
Seulement bride.. FS...S
Nur Flansch..... FS...S

Flangia completa di viti UNC, rondelle e OR..... FS...S-U
Complete flange with UNC screws, washers and o-ring..... FS...S-U
Bride complete des vis UNC, rondelles et OR..... FS...S-U
Flansch einschl. UNC-Schrauben, Federringen und O-Ring... FS...S-U

Flangia completa di viti metriche, rondelle e OR..... FS...S-M
Complete flange with metric screws, washers and o-ring..... FS...S-M
Bride complete des vis métriques, rondelles et OR..... FS...S-M
Flansch einschl. metrischen Zylinderschrauben, Federringen und O-Ring... FS...S-M

FLANGIA A 90° A SALDARE DI TESTA

90° Flanges butt welding
Bride à 90° bout a bout
90° - Winkel-Anschweißflansch

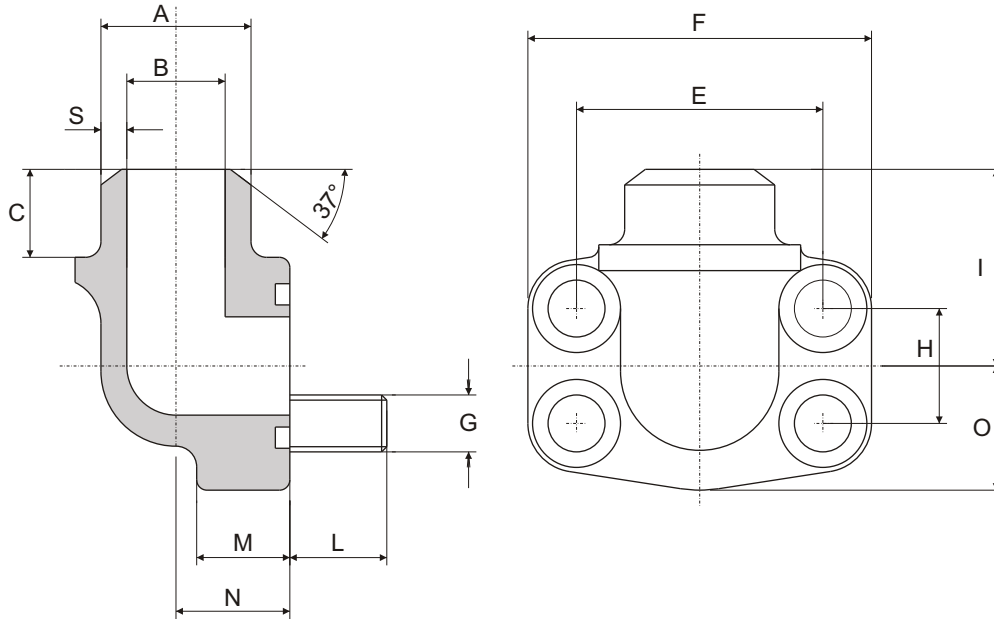

serie 3000 psi

Pressione max esercizio bar	Tipo Type	A	S.A.E.	B	C	S	E	F	G Viti / Bolts		H	I	O	M	N	L	OR O-RING
									Metr.	UNC							
348	F.S.280.90°-ST	21,6	1/2"	13	12	4,3	38	57	M 8	5/16"	17,5	40	23	17	18	13	4075
348	F.S.300.90°-ST	27,2	3/4"	19	12	4,1	47,6	68	M 8	3/8"	22,2	41	25	18	22	15	4100
348	F.S.302.90°-ST	34,5	1"	25	13	4,7	52,4	74	M10	3/8"	26,2	50	27	19	28	15	4131
278	F.S.304.90°-ST	42,8	1 1/4"	31	13	6	58,7	81	M10	7/16"	30,2	57	34	22	30	17	4150
210	F.S.306.90°-ST	48,6	1 1/2"	38	14	5,3	69,85	95	M10	1/2"	35,7	66	39	25	36	18	4187
210	F.S.308.90°-ST	61	2"	50	15	5,5	77,8	105	M12	1/2"	42,9	66	44	25	41	18	4225
175	F.S.310.90°-ST	76,6	2 1/2"	60	25	8	88,9	115	M12	1/2"	50,8	77	50	25	50	18	4275

serie 6000 psi

Pressione max esercizio bar	Tipo Type	A	S.A.E.	B	C	S	E	F	G Viti / Bolts		H	I	O	M	N	L	OR O-RING
									Metr.	UNC							
420	F.S.580.90°-ST	21,6	1/2"	13	12	4,3	40,5	57	M 8	5/16"	18,3	40	23	17	18	13	4075
420	F.S.600.90°-ST	27,2	3/4"	18	12	4,6	50,8	72	M10	3/8"	23,8	50	27	20	28	15	4100
420	F.S.602.90°-ST	34,5	1"	22	13	6,3	57,1	82	M12	7/16"	27,8	57	34	24	30	19	4131
420	F.S.604.90°-ST	42,8	1 1/4"	28	13	7,4	66,7	95	M14	1/2"	31,6	66	39	25	36	21	4150
420	F.S.606.90°-ST	48,6	1 1/2"	32	15	8,3	79,4	110	M16	5/8"	36,5	65	44	26	41	25	4187
420	F.S.608.90°-ST	61	2"	41	15	10	96,8	134	M20	3/4"	44,4	75	58	35	45	32	4225

Per ordinazione flange: / Ordering Examples: / Pour commander brides: / Bestellbeispiel für Flansche:

Solo flangia..... FS...ST Flangia completa di viti UNC, rondelle e OR..... FS...ST-U Flangia completa di viti metriche, rondelle e OR..... FS...ST-M
 Only flange..... FS...ST Complete flange with UNC screws, washers and o-ring..... FS...ST-U Complete flange with metric screws, washers and o-ring..... FS...ST-M
 Seulement bride.. FS...ST Bride complete des vis UNC, rondelles et OR..... FS...ST-U Bride complete des vis métriques, rondelles et OR..... FS...ST-M
 Nur Flansch..... FS...ST Flansch einschl. UNC-Schrauben, Federringen und O-Ring.. FS...ST-U Flansch einschl. metrischen Zylinderschrauben, Federringen und O-Ring.. FS...ST-M

FLANGIA DRITTA CON ATTACCO JIC

Straight flanges to male JIC
Bride taraudée JIC
Gerader Flansch mit JIC-Außengewinde

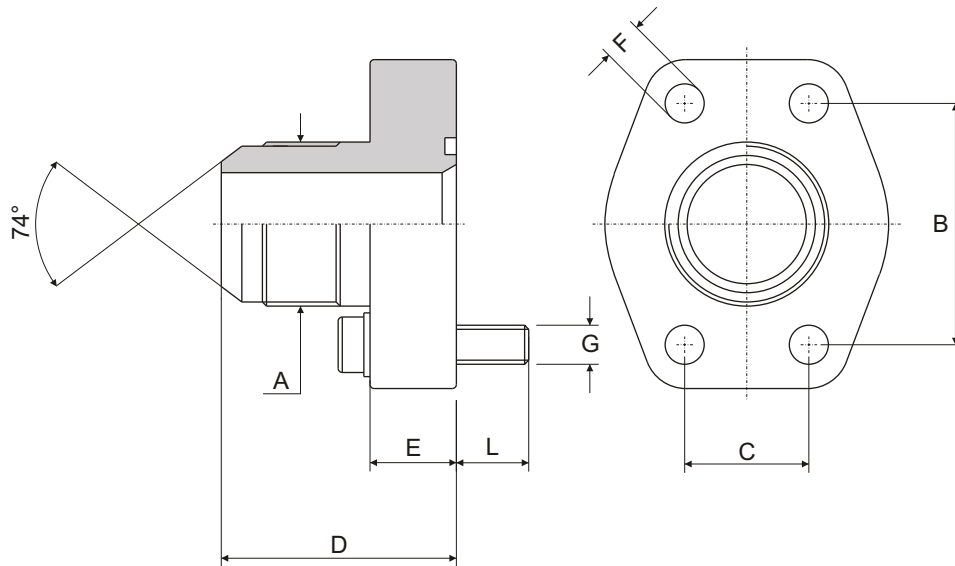

serie 3000 psi

Pressione max esercizio bar	Tipo Type	S.A.E.	A	B	C	D	E	F	G Viti / Bolts		L	OR O-RING
									Metr.	UNC		
348	JIC-080-A	1/2"	3/4" - 16	38	17,5	41	16	9	M 8	5/16"	14	4075
	JIC-080-B		7/8" - 14			41						
	JIC-080-C		1 1/16" - 12			46						
348	JIC-100-A	3/4"	7/8" - 14	47,6	22,2	47	18	11	M10	3/8"	15	4100
	JIC-100-B		1 1/16" - 12			49						
	JIC-100-C		1 5/16" - 12			50						
348	JIC-102-A	1"	1 1/16" - 12	52,4	26,2	51	18	11	M10	3/8"	15	4131
	JIC-102-B		1 5/16" - 12			52						
	JIC-102-C		1 5/8" - 12			54						
278	JIC-104-A	1" 1/4	1 5/16" - 12	58,7	30,2	56	21	11,5	M10	7/16"	18	4150
	JIC-104-B		1 5/8" - 12			58						
	JIC-104-C		1 7/8" - 12			61						
210	JIC-106-A	1" 1/2	1 5/8" - 12	69,85	35,7	64	24	13,5	M12	1/2"	20	4187
	JIC-106-B		1 7/8" - 12			67						

serie 6000 psi

Pressione max esercizio bar	Tipo Type	S.A.E.	A	B	C	D	E	F	G Viti / Bolts		L	OR O-RING
									Metr.	UNC		
420	JIC-401-A	3/8"	3/4" - 16	40,5	18,3	42	16	9	M 8	5/16"	14	4075
	JIC-401-B		7/8" - 14			45						
	JIC-401-C		1 1/16" - 12			47						
420	JIC-402-A	3/4"	7/8" - 14	50,8	23,8	49	18	11	M10	3/8"	15	4100
	JIC-402-B		1 1/16" - 12			51						
	JIC-402-C		1 5/16" - 12			52						
420	JIC-403-A	1"	1 1/16" - 12	57,1	27,8	58	21	13	M12	7/16"	18	4131
	JIC-403-B		1 5/16" - 12			59						
	JIC-403-C		1 5/8" - 12			61						
420	JIC-404-A	1" 1/4	1 5/16" - 12	66,7	31,6	64	24	15	M14	1/2"	20	4150
	JIC-404-B		1 5/8" - 12			66						
	JIC-404-C		1 7/8" - 12			69						
420	JIC-405-A	1" 1/2	1 5/8" - 12	79,4	36,5	70	27	17	M16	5/8"	20	4187
	JIC-405-B		1 7/8" - 12			73						

Per ordinazione flange: / Ordering Examples: / Pour commander brides: / Bestellbeispiel für Flansche:

Solo flangia..... JIC...ABC Flangia completa di viti UNC, rondelle e OR JIC...ABC-U Flangia completa di viti metriche, rondelle e OR JIC...ABC-M
 Only flange..... JIC...ABC Complete flange with UNC screws, washers and o-ring JIC...ABC-U Complete flange with metric screws, washers and o-ring JIC...ABC-M
 Seulement bride... JIC...ABC Bride complete des vis UNC, rondelles et OR JIC...ABC-U Bride complete des vis métriques, rondelles et OR JIC...ABC-M
 Nur Flansch..... JIC...ABC Flansch einschl. UNC-Schrauben, Federringen und O-Ring... JIC...ABC-U Flansch einschl. metrischen Zylinderschrauben, Federringen und O-Ring... JIC...ABC-M

FLANGIA A 90° CON ATTACCO JIC

90° Flanges to male JIC
Bride à 90° taraudée JIC
90° Winkelflansch mit JIC-Außengewinde

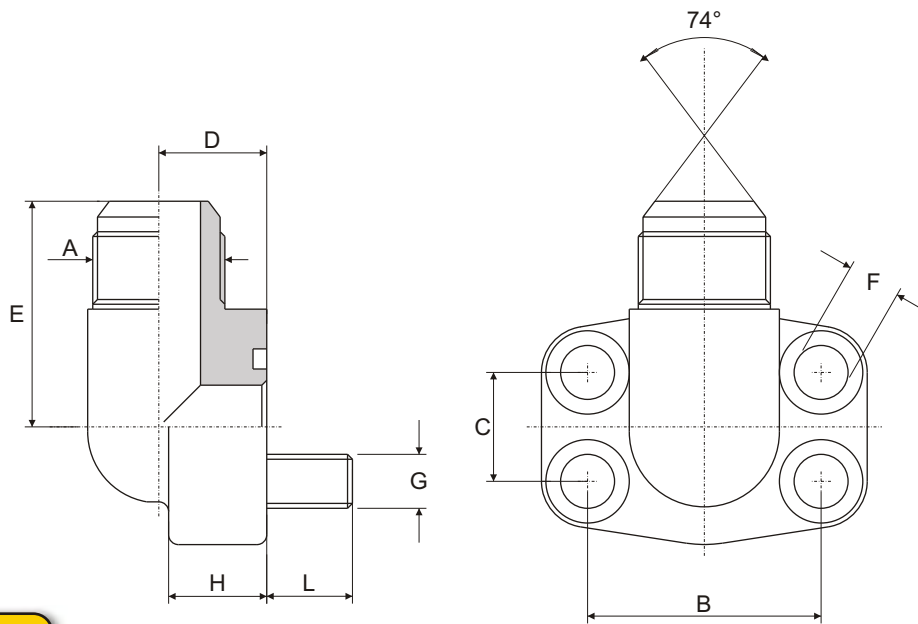

serie 3000 psi

Pressione max esercizio bar	Tipo Type	S.A.E.	A	B	C	D	E	F	G Viti / Bolts		H	L	OR O-RING
									Metr.	UNC			
348	JIC-300-90°-A	1/2"	3/4" - 16	38	17,5	17	40	9	M 8	5/16"	16	14	4075
	JIC-300-90°-B		7/8" - 14			17	42						
	JIC-300-90°-C		1 1/16" - 12			20	43						
348	JIC-301-90°-A	3/4"	7/8" - 14	47,6	22,2	20	45	11	M10	3/8"	18	14	4100
	JIC-301-90°-B		1 1/16" - 12			20	47						
	JIC-301-90°-C		1 5/16" - 12			25	48						
348	JIC-302-90°-A	1"	1 1/16" - 12	52,4	26,2	20	50	11	M10	3/8"	19	15	4131
	JIC-302-90°-B		1 5/16" - 12			25	51						
	JIC-302-90°-C		1 7/8" - 12			31	58						
278	JIC-304-90°-A	1 1/4"	1 5/16" - 12	58,7	30,2	25	56	11,5	M10	7/16"	22	18	4150
	JIC-304-90°-B		1 5/8" - 12			31	58						
	JIC-304-90°-C		1 7/8" - 12			37	61						
210	JIC-306-90°-A	1 1/2"	1 5/8" - 12	69,85	35,7	31	63	13,5	M12	1/2"	25	20	4187
	JIC-306-90°-B		1 7/8" - 12			37	66						

serie 6000 psi

Pressione max esercizio bar	Tipo Type	S.A.E.	A	B	C	D	E	F	G Viti / Bolts		H	L	OR O-RING
									Metr.	UNC			
420	JIC-600-90°-A	1/2"	3/4" - 16	40,5	18,3	17	40	9	M 8	5/16"	16	14	4075
	JIC-600-90°-B		7/8" - 14			17	42						
	JIC-600-90°-C		1 1/16" - 12			20	43						
420	JIC-601-90°-A	3/4"	7/8" - 14	50,8	23,8	20	49	11	M10	3/8"	19	14	4100
	JIC-601-90°-B		1 1/16" - 12			20	51						
	JIC-601-90°-C		1 5/16" - 12			25	52						
420	JIC-602-90°-A	1"	1 1/16" - 12	57,1	27,8	25	55	13	M12	7/16"	24	18	4131
	JIC-602-90°-B		1 5/16" - 12			25	56						
	JIC-602-90°-C		1 5/8" - 12			31	58						
420	JIC-604-90°-A	1 1/4"	1 5/16" - 12	66,7	31,6	31	56	15	M14	1/2"	25	18	4150
	JIC-604-90°-B		1 5/8" - 12			31	63						
	JIC-604-90°-C		1 7/8" - 12			37	63						
420	JIC-606-90°-A	1 1/2"	1 5/8" - 12	79,4	36,5	37	67	17	M16	5/8"	26	20	4187
	JIC-606-90°-B		1 7/8" - 12			37	70						

Per ordinazione flange: / Ordering Examples: / Pour commander brides: / Bestellbeispiel für Flansche:

Solo flangia..... JIC...ABC Flangia completa di viti UNC, rondelle e OR JIC...ABC-U Flangia completa di viti metriche, rondelle e OR JIC...ABC-M
 Only flange..... JIC...ABC Complete flange with UNC screws, washers and o-ring JIC...ABC-U Complete flange with metric screws, washers and o-ring JIC...ABC-M
 Seulement bride... JIC...ABC Bride complete des vis UNC, rondelles et OR JIC...ABC-U Bride complete des vis métriques, rondelles et OR JIC...ABC-M
 Nur Flansch..... JIC...ABC Flansch einschl. UNC-Schrauben, Federringen und O-Ring... JIC...ABC-U Flansch einschl. metrischen Zylinderschrauben, Federringen und O-Ring... JIC...ABC-M

FLANGIA DRITTA FILETTATA GAS ESTERNO

Straight flanges to BSP male
Bride taraudée BSP mâle
Gerader Flansch mit BSP-Aussengewinde

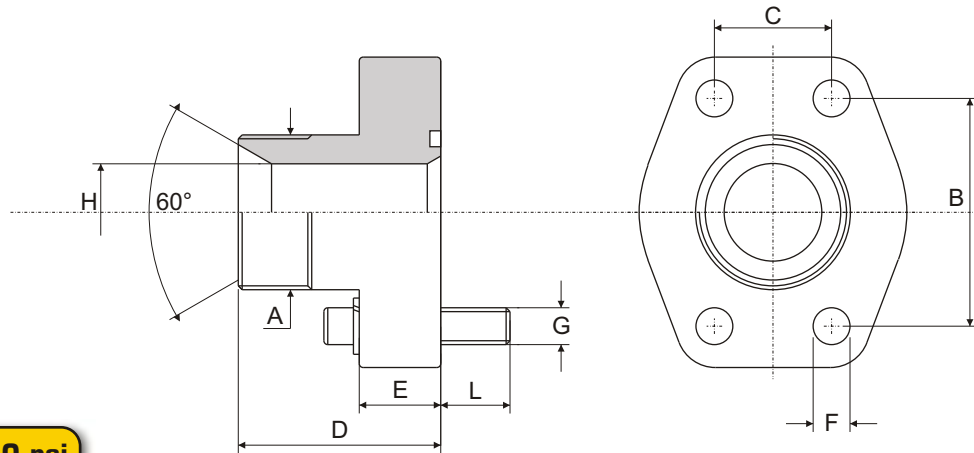

serie 3000 psi

Pressione max esercizio bar	Tipo Type	S.A.E.	A	B	C	D	E	F	G Viti / Bolts		H	L	OR O-RING
									Metr.	UNC			
348	FGE-080-A	1/2"	3/8"	38	17,5	37	16	9	M 8	5/16"	10	14	4075
	FGE-080-B		1/2"			39					12		
	FGE-080-C		3/4"			42					13		
348	FGE-100-A	3/4"	1/2"	47,6	22,2	42	18	11	M10	3/8"	12	14	4100
	FGE-100-B		3/4"			45					17		
	FGE-100-C		1"			47					19		
348	FGE-102-A	1"	3/4"	52,4	26,2	47	18	11	M10	3/8"	17	14	4131
	FGE-102-B		1"			49					22		
	FGE-102-C		1" 1/4			49					25		
278	FGE-104-A	1" 1/4	1"	58,7	30,2	53	21	11,5	M10	7/16"	22	18	4150
	FGE-104-B		1" 1/4			53					27		
	FGE-104-C		1" 1/2			55					31		
210	FGE-106-A	1" 1/2	1" 1/4	69,85	35,7	59	24	13,5	M12	1/2"	27	18	4187
	FGE-106-B		1" 1/2			61					34		
	FGE-106-C		2"			63					38		
210	FGE-108-A	2"	1" 1/2	77,8	42,9	69	25	13,5	M12	1/2"	34	19	4225
	FGE-108-B		2"			69					42		

serie 6000 psi

Pressione max esercizio bar	Tipo Type	S.A.E.	A	B	C	D	E	F	G Viti / Bolts		H	L	OR O-RING
									Metr.	UNC			
420	FGE-401-A	1/2"	3/8"	40,5	18,2	38	16	9	M 8	5/16"	10	14	4075
	FGE-401-B		1/2"			40					12		
	FGE-401-C		3/4"			43					13		
420	FGE-402-A	3/4"	1/2"	50,8	23,8	44	18	11	M10	3/8"	12	14	4100
	FGE-402-B		3/4"			47					17		
	FGE-402-C		1"			49					19		
420	FGE-403-A	1"	3/4"	57,1	27,8	54	21	13	M12	7/16"	17	18	4131
	FGE-403-B		1"			56					22		
	FGE-403-C		1" 1/4			56					25		
420	FGE-404-A	1" 1/4	1"	66,7	31,6	61	24	15	M14	1/2"	22	18	4150
	FGE-404-B		1" 1/4			61					27		
	FGE-404-C		1" 1/2			63					31		
420	FGE-405-A	1" 1/2	1" 1/4	79,4	36,5	65	27	17	M16	5/8"	27	20	4187
	FGE-405-B		1" 1/2			67					32		

Per ordinazione flange: / Ordering Examples: / Pour commander brides: / Bestellbeispiel für Flansche:

Solo flangia.....FGE...ABC Flangia completa di viti UNC, rondelle e OR.....FGE...ABC-U Flangia completa di viti metriche, rondelle e OR.....FGE...ABC-M
 Only flange.....FGE...ABC Complete flange with UNC screws, washers and o-ring.....FGE...ABC-U Complete flange with metric screws, washers and o-ring.....FGE...ABC-M
 Seulement bride..FGE...ABC Bride complete des vis UNC, rondelles et OR.....FGE...ABC-U Bride complete des vis métriques, rondelles et OR.....FGE...ABC-M
 Nur Flansch.....FGE...ABC Flansch einschl. UNC-Schrauben, Federringen und O-Ring..FGE...ABC-U Flansch einschl. metrischen Zylinderschrauben, Federringen und O-Ring..FGE...ABC-M

FLANGIA A 90° FILETTATA GAS ESTERNO

90° Flanges to BSP male
Bride à 90° taraudée BSP mâle
90° Winkelflansch mit BSP-Außengewinde

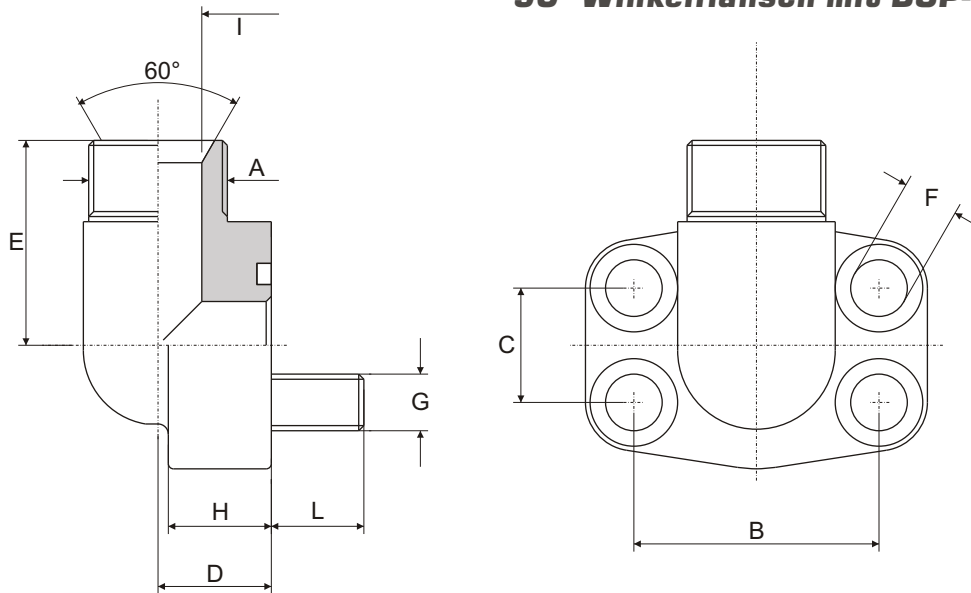

serie 3000 psi

Pressione max esercizio bar	Tipo Type	S.A.E.	A	B	C	D	E	F	G Viti / Bolts		H	I	L	OR O-RING
									Metr.	UNC				
348	FGE-300-90°-A	1/2"	3/8"	38	17,5	17	37	9	M 8	5/16"	16	10	14	4075
	FGE-300-90°-B		1/2"			17	39					12		
	FGE-300-90°-C		3/4"			20	40					13		
348	FGE-301-90°-A	3/4"	1/2"	47,6	22,2	20	41	11	M10	3/8"	18	12	14	4100
	FGE-301-90°-B		3/4"			20	44					17		
	FGE-301-90°-C		1"			25	45					19		
348	FGE-302-90°-A	1"	3/4"	52,4	26,2	20	47	11	M10	3/8"	19	17	14	4131
	FGE-302-90°-B		1"			25	48					22		
	FGE-302-90°-C		1" 1/4			31	49					25		
278	FGE-304-90°-A	1" 1/4	1"	58,7	30,2	25	54	11,5	M10	7/16"	22	22	18	4150
	FGE-304-90°-B		1" 1/4			31	55					27		
	FGE-304-90°-C		1" 1/2			37	56					31		
210	FGE-306-90°-A	1" 1/2	1" 1/4	69,85	35,7	31	59	13,5	M12	1/2"	25	27	18	4187
	FGE-306-90°-B		1" 1/2			37	61					34		

serie 6000 psi

Pressione max esercizio bar	Tipo Type	S.A.E.	A	B	C	D	E	F	G Viti / Bolts		H	I	L	OR O-RING
									Metr.	UNC				
420	FGE-600-90°-A	1/2"	3/8"	40,5	18,2	17	37	9	M 8	5/16"	16	10	14	4075
	FGE-600-90°-B		1/2"			17	39					12		
	FGE-600-90°-C		3/4"			20	40					13		
420	FGE-601-90°-A	3/4"	1/2"	50,8	23,8	20	45	11	M10	3/8"	19	12	14	4100
	FGE-601-90°-B		3/4"			20	48					17		
	FGE-601-90°-C		1"			25	50					19		
420	FGE-602-90°-A	1"	3/4"	57,1	27,8	25	52	13	M12	7/16"	24	17	18	4131
	FGE-602-90°-B		1"			25	54					22		
	FGE-602-90°-C		1" 1/4			31	55					25		
420	FGE-604-90°-A	1" 1/4	1"	66,7	31,6	31	59	15	M14	1/2"	25	22	18	4150
	FGE-604-90°-B		1" 1/4			31	59					27		
	FGE-604-90°-C		1" 1/2			37	61					31		
420	FGE-606-90°-A	1" 1/2	1" 1/4	79,4	36,5	37	64	17	M16	5/8"	26	27	20	4187
	FGE-606-90°-B		1" 1/2			37	66					32		

Per ordinazione flange: / Ordering Examples: / Pour commander brides: / Bestellbeispiel für Flansche:

Solo flangia..... FGE...ABC Flangia completa di viti UNC, rondelle e OR..... FGE...ABC-U Flangia completa di viti metriche, rondelle e OR..... FGE...ABC-M
 Only flange..... FGE...ABC Complete flange with UNC screws, washers and o-ring..... FGE...ABC-U Complete flange with metric screws, washers and o-ring..... FGE...ABC-M
 Seulement bride.. FGE...ABC Bride complete des vis UNC, rondelles et OR..... FGE...ABC-U Bride complete des vis métriques, rondelles et OR..... FGE...ABC-M
 Nur Flansch..... FGE...ABC Flansch einschl. UNC-Schrauben, Federringen und O-Ring.. FGE...ABC-U Flansch einschl. metrischen Zylinderschrauben, Federringen und O-Ring.. FGE...ABC-M

FLANGIA FILETTATA METRICA DIN 2353

Flanges with metric thread according with DIN 2353
Bride taraudée métrique DIN 2353

Gerader Flansch mit Schneidring-Anschluß nach DIN 2353

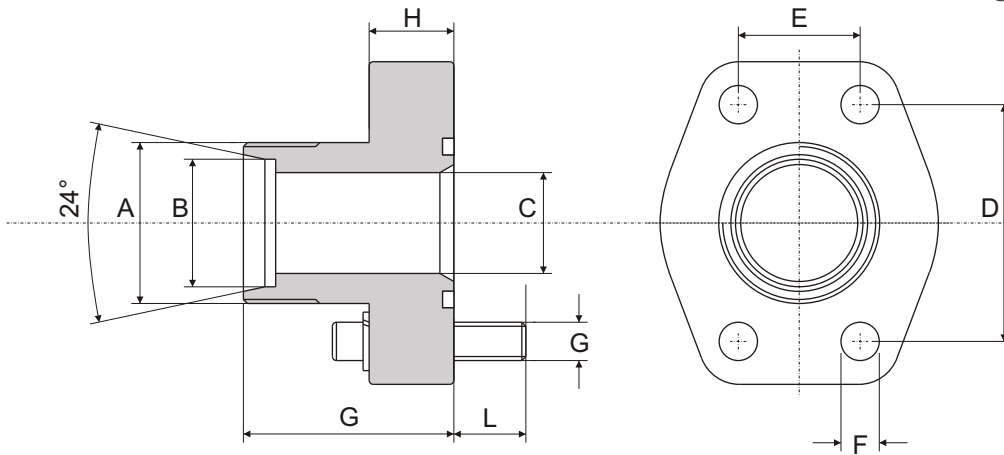

La misura "B" può essere variata a seconda delle esigenze del cliente.
Measurement "B" can be changed according to customer's requests.
La mesure "B" peut être changé selon les exigences de la clientèle.
Auch für andere abmessungen "B" nach vorgabe Lieferbar.

serie 3000 psi

Pressione max esercizio bar	Tipo Type	S.A.E.	A	B	C	D	E	F	G	H	G Viti / Bolts		L	OR O-RING
											Metr.	UNC		
348	FME-080-12S	1/2"	20x1,5	12	8	38	17,5	9	47	16	M 8	5/16"	14	4075
	FME-080-15L		22x1,5	15	11									
	FME-080-16S		24x1,5	16	12									
348	FME-100-16S	3/4"	24x1,5	16	12	47,6	22,2	11	52	18	M10	3/8"	14	4100
	FME-100-20S		30x2	20	16									
	FME-100-22L		30x2	22	18									
348	FME-102-20S	1"	30x2	20	16	52,4	26,2	11	55	18	M10	3/8"	14	4131
	FME-102-25S		36x2	25	20									
	FME-102-28L		36x2	28	23									
278	FME-104-25S	1" 1/4	36x2	25	20	48,7	30,2	11,5	60	21	M10	7/16"	18	4150
	FME-104-30S		42x2	30	25									
	FME-104-35L		45x2	35	30									
210	FME-106-35L	1" 1/2	45x2	35	30	69,85	35,7	13,5	70	25	M12	1/2"	18	4187
	FME-106-38S		52x2	38	32									
	FME-106-42L		52x2	42	36									
210	FME-108-42L	2"	52x2	42	32	77,8	42,9	13,5	74	25	M12	1/2"	18	4225
	FME-108-38S		52x2	38	36									

serie 6000 psi

Pressione max esercizio bar	Tipo Type	S.A.E.	A	B	C	D	E	F	G	H	G Viti / Bolts		L	OR O-RING
											Metr.	UNC		
420	FME-401-12S	1/2"	20x1,5	12	8	40,5	18,3	9	47	16	M 8	5/16"	14	4075
	FME-401-14S		22x1,5	14	10									
	FME-401-16S		24x1,5	16	12									
420	FME-402-16S	3/4"	24x1,5	16	12	50,8	23,8	11	52	18	M10	3/8"	14	4100
	FME-402-20S		30x2	20	16									
	FME-402-22L		30x2	22	18									
420	FME-403-20S	1"	30x2	20	16	57,1	27,8	13	60	21	M12	7/16"	14	4131
	FME-403-25S		36x2	25	20									
	FME-403-28L		36x2	28	23									
420	FME-404-25S	1" 1/4	36x2	25	20	66,7	31,6	15	68	24	M14	1/2"	18	4150
	FME-404-30S		42x2	30	25									
	FME-404-35L		45x2	35	30									
420	FME-405-30S	1" 1/2	42x2	30	25	79,4	36,5	17	72	27	M16	5/8"	20	4187
	FME-405-38S		52x2	38	32									
	FME-405-42L		52x2	42	36									

Per ordinazione flange: / Ordering Examples: / Pour commander brides: / Bestellbeispiel für Flansche:

Solo flangia..... FME...
Only flange..... FME...
Seulement bride... FME...
Nur Flansch..... FME...

Flangia completa di viti UNC, rondelle e OR.....FME...U
Complete flange with UNC screws, washers and o-ring.....FME...U
Bride complete des vis UNC, rondelles et OR.....FME...U
Flansch einschl. UNC-Schrauben, Federringen und O-Ring...FME...U

Flangia completa di viti metriche, rondelle e OR..... FME...M
Complete flange with metric screws, washers and o-ring..... FME...M
Bride complete des vis métriques, rondelles et OR..... FME...M
Flansch einschl. metrischen Zylinderschrauben, Federringen und O-Ring...FME...M

FLANGIA A 90° FILETTATA METRICA DIN 2353 — 90° Flanges with metric thread in according with DIN 2353

Bride à 90° taradée métrique DIN 2353
90° Winkelflansch mit Schneidring-Anschluß nach DIN 2353

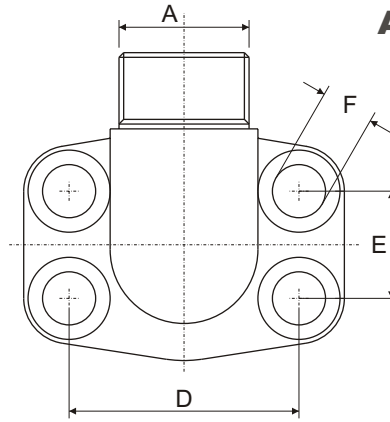
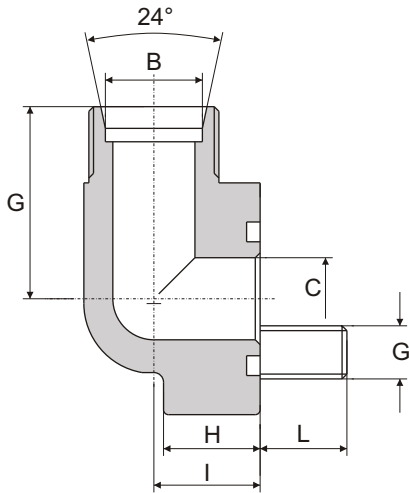

La misura "B" può essere variata a seconda delle esigenze del cliente.
 Measurement "B" can be changed according to customer's requests.
 La mesure "B" peut être changé selon les exigences de la clientèle.
 Auch für andere abmessungen "B" nach vorgabe Lieferbar.

serie 3000 psi

Pressione max esercizio bar	Tipo Type	S.A.E.	A	B	C	D	E	F	G	H	I	G Viti / Bolts		L	OR O-RING	
												Metr.	UNC			
348	FME-300-12S	1/2"	20x1,5	12	8	38	17,5	9	36	16	18		M 8	5/16"	14	4075
	FME-300-15L		22x1,5	15	11											
	FME-300-16S		24x1,5	16	12											
348	FME-301-16S	3/4"	24x1,5	16	12	47,6	22,2	11	38	18	22		M10	3/8"	14	4100
	FME-301-20S		30x2	20	16											
	FME-301-22L		30x2	22	18											
348	FME-302-20S	1"	30x2	20	16	52,4	26,2	11	42	19	28		M10	3/8"	14	4131
	FME-302-25S		36x2	25	20											
	FME-302-28L		36x2	28	23											
278	FME-304-25S	1" 1/4	36x2	25	20	58,7	30,2	11,5	50	22	30		M10	7/16"	18	4150
	FME-304-30S		42x2	30	25											
	FME-304-35L		45x2	35	30											
210	FME-306-35L	1" 1/2	45x2	35	30	69,85	35,7	13,5	58	25	36		M12	1/2"	18	4187
	FME-306-38S		52x2	38	32											
	FME-306-42L		52x2	42	36											

serie 6000 psi

Pressione max esercizio bar	Tipo Type	S.A.E.	A	B	C	D	E	F	G	H	I	G Viti / Bolts		L	OR O-RING	
												Metr.	UNC			
420	FME-600-12S	1/2"	20x1,5	12	8	40,5	18,3	9	36	16	20		M 8	5/16"	14	4075
	FME-600-14S		22x1,5	14	10											
	FME-600-16S		24x1,5	16	12											
420	FME-601-16S	3/4"	24x1,5	16	12	50,8	23,8	11	41	19	26		M10	3/8"	14	4100
	FME-601-20S		30x2	20	20											
	FME-601-22L		30x2	22	23											
420	FME-602-20S	1"	30x2	20	16	57,1	27,8	13	50	24	30		M12	7/16"	14	4131
	FME-602-25S		36x2	25	20											
	FME-602-28L		36x2	28	23											
420	FME-604-25L	1" 1/4	36x2	25	20	66,7	31,6	15	58	25	36		M14	1/2"	18	4150
	FME-604-30S		42x2	30	25											
	FME-604-35L		45x2	35	30											
420	FME-606-30S	1" 1/2	42x2	30	25	79,4	36,5	17	65	26	41		M16	5/8"	18	4187
	FME-606-38S		52x2	38	32											
	FME-606-42L		52x2	42	36											

Per ordinazione flange: / Ordering Examples: / Pour commander brides: / Bestellbeispiel für Flansche:

Solo flangia..... FME...U Flangia completa di viti UNC, rondelle e OR..... FME...U Complete flange with UNC screws, washers and o-ring..... FME...M Flangia completa di viti metriche, rondelle e OR..... FME...M Only flange..... FME...U Bride complete des vis UNC, rondelles et OR..... FME...U Complete flange with metrical screws, washers and o-ring..... FME...M Seulement bride... FME...U Flansch einschl. UNC-Schrauben, Federringen und O-Ring... FME...U 90° Winkelflansch mit Schneidring-Anschluß nach DIN 2353..... FME...M Nur Flansch..... FME...U

FLANGIA DRITTA TENUTA FRONTALE ORFS

**Straight flanges
O-Ring face seal
Bride ORFS**

Gerader Flansch O-Ring flachdichtend

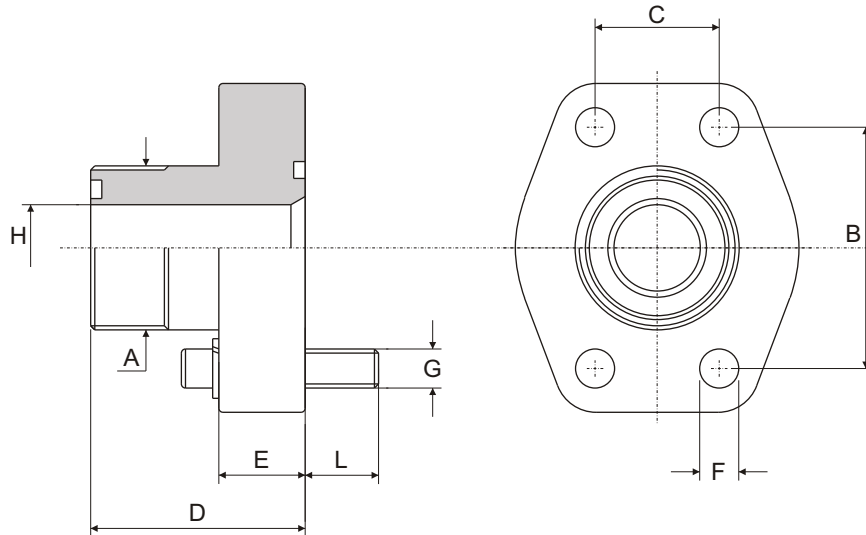

serie 3000 psi

Pressione max esercizio bar	Tipo Type	S.A.E.	A	B	C	D	E	F	G Viti / Bolts		H	L	OR O-RING
									Metr.	UNC			
348	ORFS.080-A	1/2"	11/16" - 16	38	17,5	37	16	9	M 8	5/16"	6	14	4075
	ORFS.080-B		13/16" - 16			39					9		
	ORFS.080-C		1" - 14			42					12		
348	ORFS.100-A	3/4"	1" - 14	47,6	22,2	45	18	11	M10	3/8"	12	14	4100
	ORFS.100-B		1 3/16" - 12			47					15		
348	ORFS.102-A	1"	1 3/16" - 12	52,4	26,2	49	18	11	M10	3/8"	15	14	4131
	ORFS.102-B		1 7/16" - 12			20							
278	ORFS.104-A	1 1/4"	1 7/16" - 12	58,7	30,2	53	21	11,5	M10	7/16"	20	18	4150
	ORFS.104-B		1 11/16" - 12			26							
210	ORFS.106-A	1 1/2"	1 11/16" - 12	69,85	35,7	61	24	13,5	M12	1/2"	26	19	4187
	ORFS.106-B		2" - 12			32							

serie 6000 psi

Pressione max esercizio bar	Tipo Type	S.A.E.	A	B	C	D	E	F	G Viti / Bolts		H	L	OR O-RING
									Metr.	UNC			
420	ORFS.401-A	1/2"	11/16" - 16	40,5	18,2	38	16	9	M 8	5/16"	6	14	4075
	ORFS.401-B		13/16" - 16			40					9		
	ORFS.401-C		1" - 14			43					12		
420	ORFS.402-A	3/4"	1" - 14	50,8	23,8	47	18	11	M10	3/8"	12	14	4100
	ORFS.402-B		1 3/16" - 12			49					15		
420	ORFS.403-A	1"	1 3/16" - 12	57,1	27,8	56	21	13	M12	7/16"	15	18	4131
	ORFS.403-B		1 7/16" - 12			20							
420	ORFS.404-A	1 1/4"	1 7/16" - 12	66,7	31,6	61	24	15	M14	1/2"	20	18	4150
	ORFS.404-B		1 11/16" - 12			26							
420	ORFS.405-A	1 1/2"	1 11/16" - 12	79,4	36,5	65	27	17	M16	5/8"	26	20	4187
	ORFS.405-B		2" - 12			67					32		

Per ordinazione flange: / Ordering Examples: / Pour commander brides: / Bestellbeispiel für Flansche:

Solo flangia..... ORFS...ABC Flangia completa di viti UNC, rondelle e OR..... ORFS...ABC-U Flangia completa di viti metriche, rondelle e OR..... ORFS...ABC-M
 Only flange..... ORFS...ABC Complete flange with UNC screws, washers and o-ring..... ORFS...ABC-U Complete flange with metric screws, washers and o-ring..... ORFS...ABC-M
 Seulment bride... ORFS...ABC Bride complete des vis UNC, rondelles et OR..... ORFS...ABC-U Bride complete des vis métriques, rondelles et OR..... ORFS...ABC-M
 Nur Flansch..... ORFS...ABC Flansch einsch. UNC-Schrauben, Federringen und O-Ring.. ORFS...ABC-U Flansch einsch. metrischen Zylinderschrauben, Federringen und O-Ring.. ORFS...ABC-M

FLANGIA A 90° TENUTA FRONTALE OR

90° Flange O-Ring face seal
Bride à 90° ORFS
90°- Flansch O-Ring flachdichtend

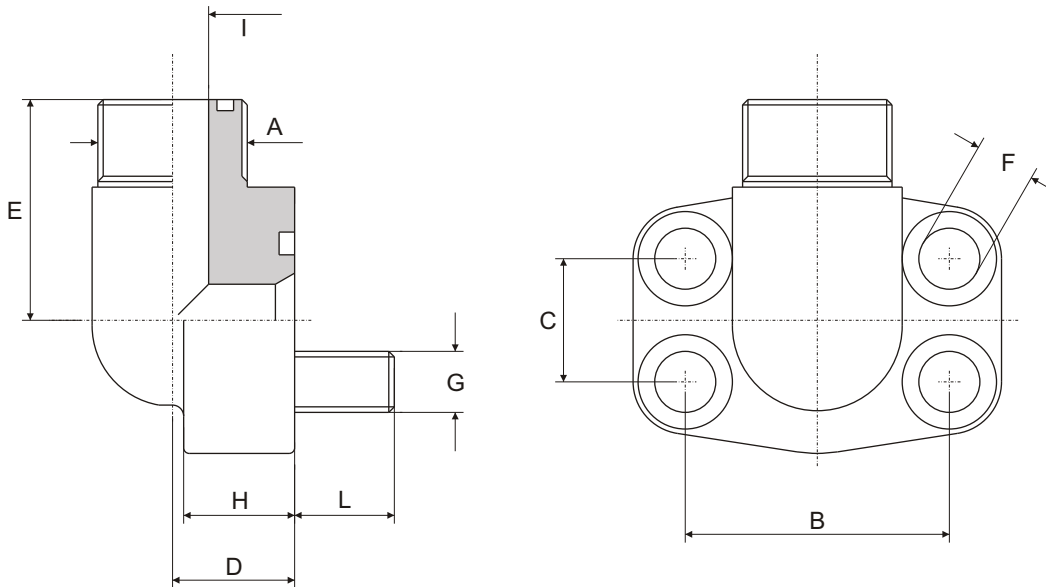

serie 3000 psi

Pressione max esercizio bar	Tipo Type	S.A.E.	A	B	C	D	E	F	G Viti / Bolts		H	I	L	OR O-RING	
									Metr.	UNC					
348	ORFS-300-90°-A	1/2"	11/16" - 16	38	17,5	17	37	9	M 8	5/16"	16	6	14	4075	
	ORFS-300-90°-B		13/16" - 16												12
	ORFS-300-90°-C		1" - 14												
348	ORFS-301-90°-A	3/4"	1" - 14	47,6	22,2	20	44	11	M10	3/8"	18	12	14	4100	
	ORFS-301-90°-B		1 3/16 - 12												15
348	ORFS-302-90°-A	1"	1 3/16 - 12	52,4	26,2	25	48	11	M10	3/8"	19	15	14	4131	
	ORFS-302-90°-B		1 7/16 - 12												20
278	ORFS-304-90°-A	1 1/4"	1 7/16 - 12	58,7	30,2	31	55	11,5	M10	7/16"	22	20	18	4150	
	ORFS-304-90°-B		1 11/16 - 12												26
210	ORFS-306-90°-A	1 1/2"	1 11/16 - 12	69,85	35,7	31	59	13,5	M12	1/2"	25	26	18	4187	
	ORFS-306-90°-B		2" - 12												32

serie 6000 psi

Pressione max esercizio bar	Tipo Type	S.A.E.	A	B	C	D	E	F	G Viti / Bolts		L	H	L	OR O-RING	
									Metr.	UNC					
420	ORFS-600-90°-A	1/2"	11/16" - 16	40,5	18,2	17	37	9	M 8	5/16"	16	6	14	4075	
	ORFS-600-90°-B		13/16" - 16												12
	ORFS-600-90°-C		1" - 14												
420	ORFS-601-90°-A	3/4"	1" - 14	50,8	23,8	20	48	11	M10	3/8"	19	12	14	4100	
	ORFS-601-90°-B		1 3/16 - 12												15
420	ORFS-602-90°-A	1"	1 3/16 - 12	57,1	27,8	25	54	13	M12	7/16"	24	15	18	4131	
	ORFS-602-90°-B		1 7/16 - 12												20
420	ORFS-604-90°-A	1 1/4"	1 7/16 - 12	66,7	31,6	31	59	15	M14	1/2"	25	20	18	4150	
	ORFS-604-90°-B		1 11/16 - 12												26
420	ORFS-606-90°-A	1 1/2"	1 11/16 - 12	79,4	36,5	37	64	17	M16	5/8"	26	26	20	4187	
	ORFS-606-90°-B		2" - 12												32

Per ordinazione flange: / Ordering Examples: / Pour commander brides: / Bestellbeispiel für Flansche:

Solo flangia.....ORFS...ABC Flangia completa di viti UNC, rondelle e OR.....ORFS...ABC-U Flangia completa di viti metriche, rondelle e OR.....ORFS...ABC-M
 Only flange.....ORFS...ABC Complete flange with UNC screws, washers and o-ring.....ORFS...ABC-U Complete flange with metrical screws, washers and o-ring.....ORFS...ABC-M
 Seulement bride.....ORFS...ABC Bride complete des vis UNC, rondelles et OR.....ORFS...ABC-U Bride complete des vis métriques, rondelles et OR.....ORFS...ABC-M
 Nur Flansch.....ORFS...ABC Flansch einsch. UNC-Schrauben, Federringen und O-Ring.....ORFS...ABC-U Flansch einsch. metrischen Zylinderschrauben, Federringen und O-Ring.....ORFS...ABC-M

ADATTATORE S.A.E.

S.A.E. Straight adapter flange
Adaptateur S.A.E.
S.A.E. Reduzier flansch gerade

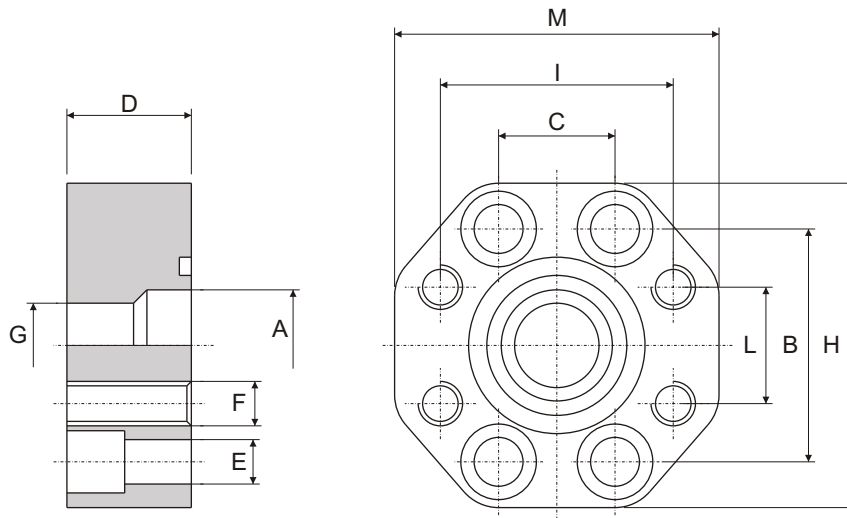

serie 3000 psi

Pressione max esercizio bar	Tipo Type	S.A.E.	A	B	C	D	E	F	G	H	I	L	M	OR O-RING
210	R.F.S. - 102-102	1" x 1"	25	52,4	26,2	28	11	M10	25	71	52,4	26,2	71	4131
210	R.F.S. - 102-100	1" x 3/4"	25	52,4	26,2	28	11	M10	19	71	47,6	22,2	71	4131
210	R.F.S. - 104-104	1 1/4 x 1 1/4	30	58,7	30,2	28	11	M10	30	80	58,7	30,2	80	4150
210	R.F.S. - 104-102	1 1/4 x 1"	30	58,7	30,2	28	11	M10	25	80	52,4	26,2	71	4150
210	R.F.S. - 106-106	1 1/2 x 1 1/2	38	69,85	35,7	32	13	M12	38	94	70	35,7	94	4187
210	R.F.S. - 106-104	1 1/2 x 1 1/4	38	69,85	35,7	32	13	M10	30	94	58,7	30,2	80	4187
210	R.F.S. - 108-108	2" x 2"	50	77,8	42,9	33	13	M12	50	103	77,8	42,9	103	4225
210	R.F.S. - 108-106	2" x 1 1/2	50	77,8	42,9	33	13	M12	38	103	69,85	35,7	94	4225
175	R.F.S. - 110-110	2 1/2 x 2 1/2	63	89	50,8	33	13	M12	63	115	89	50,8	115	4275
175	R.F.S. - 110-108	2 1/2 x 2"	63	89	50,8	33	13	M12	50	115	77,8	42,9	103	4275
138	R.F.S. - 112-112	3" x 3"	73	106,4	62	36	17	M16	73	135	106,4	62	135	4337
138	R.F.S. - 112-110	3" x 2 1/2	73	106,4	62	36	17	M12	63	135	89	50,8	115	4337

serie 6000 psi

Pressione max esercizio bar	Tipo Type	S.A.E.	A	B	C	D	E	F	G	H	I	L	M	OR O-RING
420	R.F.S. - 402-402	3/4" x 3/4"	19	50,8	23,8	28	11	M10	19	71	50,8	23,8	71	4100
420	R.F.S. - 403-403	1" x 1"	25	57,1	27,8	33	13	M12	25	80	57,1	27,8	80	4131
420	R.F.S. - 403-402	1" x 3/4"	25	57,1	27,8	33	13	M10	19	80	50,8	23,8	71	4131
420	R.F.S. - 404-404	1 1/4 x 1 1/4	30	66,7	31,6	33	15	M14	30	94	66,7	31,6	94	4150
420	R.F.S. - 404-403	1 1/4 x 1"	30	66,7	31,6	33	15	M12	25	94	57,1	27,8	80	4150
420	R.F.S. - 405-405	1 1/2 x 1 1/2	38	79,4	36,5	48	17	M16	38	106	79,4	36,5	106	4187
420	R.F.S. - 405-404	1 1/2 x 1 1/4	38	79,4	36,5	48	17	M14	30	106	66,7	31,6	94	4187
420	R.F.S. - 406-406	2" x 2"	50	96,8	44,4	48	21	M20	50	135	96,8	44,4	135	4225
420	R.F.S. - 406-405	2" x 1 1/2	50	96,8	44,4	48	21	M16	38	135	74,9	36,7	106	4225
420	R.F.S. - 408-406	2 1/2 x 2"	63	123,8	58,7	53	25	M20	50	166	96,8	44,4	150	4275
420	R.F.S. - 410-406	3" x 2"	73	152,4	71,4	58	31	M20	50	208	96,8	44,4	178	4337

BLOCCO S.A.E. 90° L

S.A.E. - 90° L - Block
 Bloc S.A.E. à 90°
 S.A.E. 90° L - Block

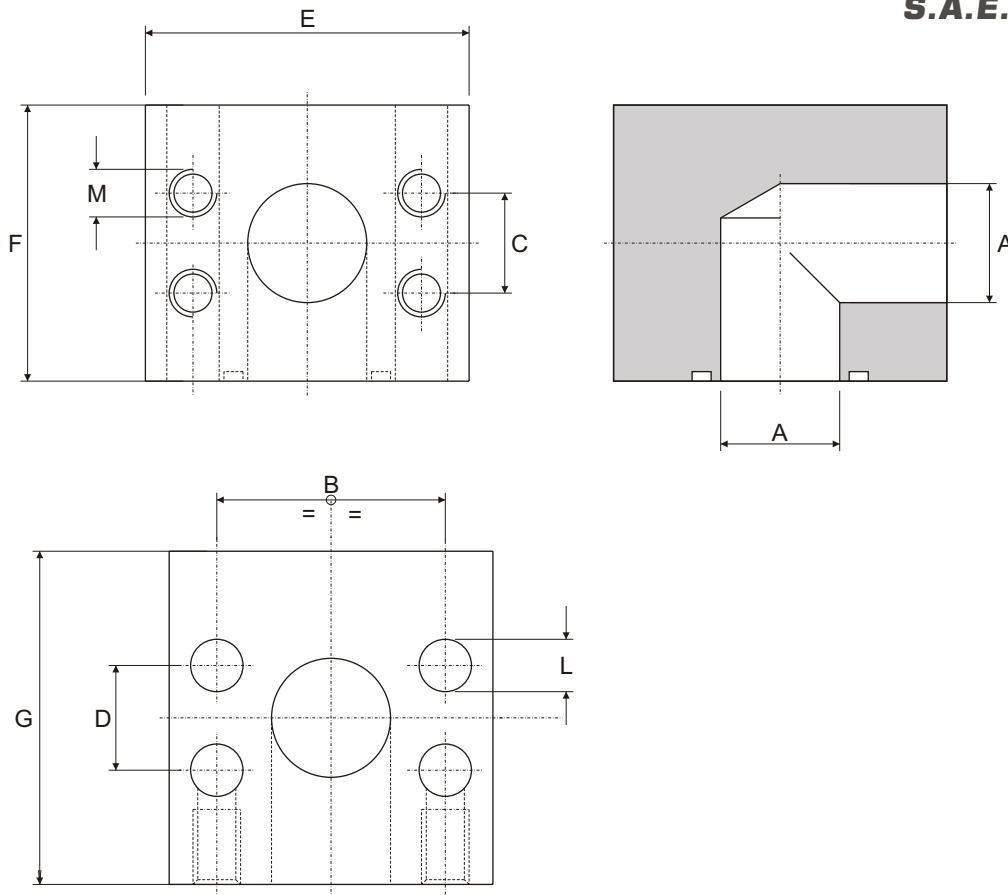

serie 3000 psi

Pressione max esercizio bar	Tipo Type	S.A.E.	A	B	C	D	E	F	G	L	M	OR O-RING
210	B.L. - 304	1" 1/4	31	58,7	30,2	30,2	80	80	80	11	M10	4150
210	B.L. - 306	1" 1/2	38	69,85	35,7	35,7	94	94	94	13,5	M12	4187
210	B.L. - 308	2"	50	77,8	42,9	42,9	103	87	87	13,5	M12	4225

serie 6000 psi

Pressione max esercizio bar	Tipo Type	S.A.E.	A	B	C	D	E	F	G	L	M	OR O-RING
420	B.L. - 600	3/4"	19	50,8	23,8	23,8	70	55	60	11	M10	4100
420	B.L. - 602	1"	25	57,1	27,8	27,8	80	69	69	13	M12	4131
420	B.L. - 604	1" 1/4	30	66,7	31,6	31,6	94	75	75	15	M14	4150
420	B.L. - 606	1" 1/2	38	79,4	36,5	36,5	106	89	89	17	M16	4187
420	B.L. - 608	2"	50	96,8	44,4	44,4	135	116	116	21	M20	4225

Per ordinazione: / Ordering Examples: / Pour commander: / Bestellbeispiel:

Blocco S.A.E. 90° L B.L.
 S.A.E. - 90° - L - Block B.L.
 Bloc S.A.E. à 90° B.L.
 S.A.E. 90° L - Block B.L.



BLOCCO S.A.E. 90° L RIDOTTO

S.A.E. 90° L reduction
Bloc S.A.E. à 90° réduit
S.A.E. 90° L reduzierblock

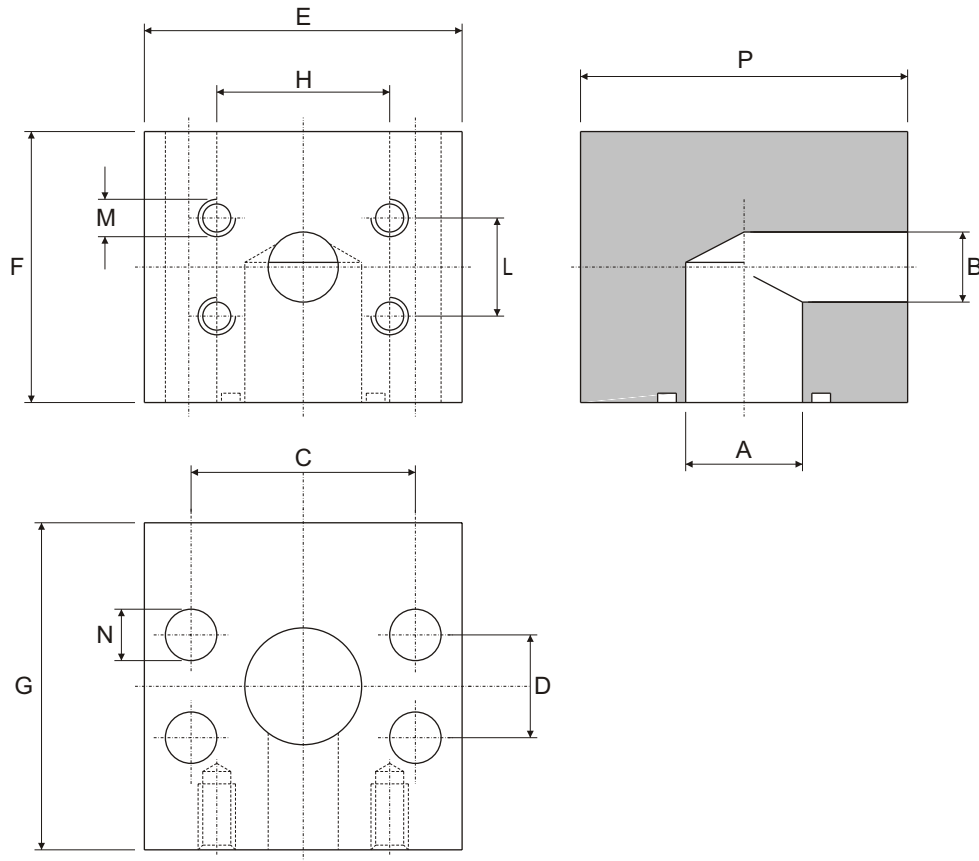

serie 6000 psi

Pressione max esercizio bar	Tipo Type	S.A.E.	A	B	C	D	E	F	G	H	L	M	N	OR O-RING
420	B.L.R. - 403-402	1"	25	19	57,1	27,8	80	69	69	50,8	23,8	M10	13	4131
420	B.L.R. - 404-402	1" 1/4	30	19	66,7	31,6	94	75	75	50,8	23,8	M10	15	4150
420	B.L.R. - 404-403	1" 1/4	30	25	66,7	31,6	94	75	75	57,1	27,8	M12	15	4150
420	B.L.R. - 405-404	1" 1/2	38	30	79,4	36,5	106	89	89	66,7	31,6	M14	17	4187
420	B.L.R. - 406-405	2"	50	38	96,8	44,4	135	116	116	79,4	36,5	M16	21	4225

Per ordinazione: / Ordering Examples: / Pour commander: / Bestellbeispiel:

Blocco S.A.E. 90° L ridotto..... B.L.R.....
 S.A.E. 90° L reduction..... B.L.R.....
 Bloc S.A.E. à 90° réduit..... B.L.R.....
 S.A.E. 90° L reduzierblock..... B.L.R.....



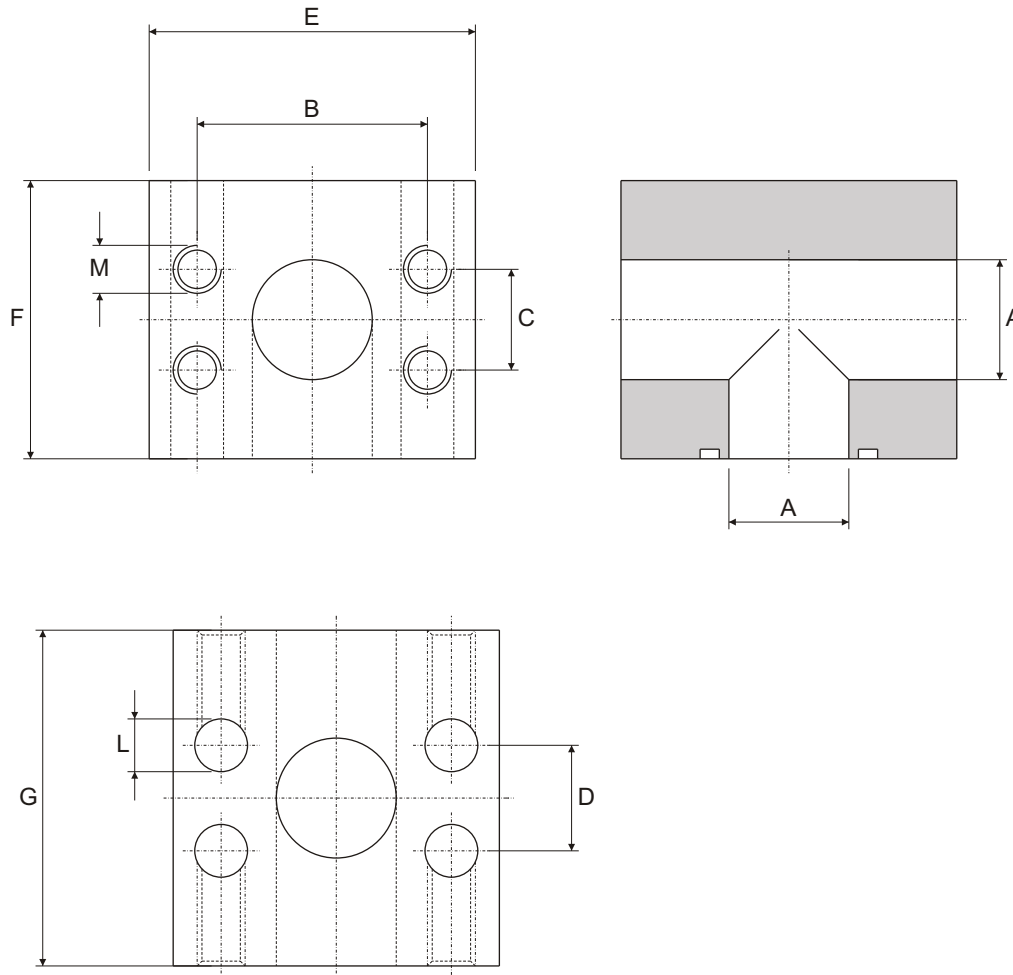

serie 6000 psi

Pressione max esercizio bar	Tipo Type	S.A.E.	A	B	C	D	E	F	G	L	M	OR O-RING
420	B.T. - 600-600	3/4"	19	50,8	23,8	23,8	70	55	70	11	M10	4100
420	B.T. - 602-602	1"	25	57,1	27,8	27,8	80	69	80	13	M12	4131
420	B.T. - 604-604	1" 1/4	30	66,7	31,6	31,6	94	75	94	15	M14	4150
420	B.T. - 606-606	1" 1/2	38	79,4	36,5	36,5	106	100	106	17	M16	4187
420	B.T. - 608-608	2"	50	96,8	44,4	44,4	135	116	140	21	M20	4225

Per ordinazione: / Ordering Examples: / Pour commander: / Bestellbeispiel:

Blocco S.A.E. a T..... B.T.....
 S.A.E. T - block B.T.....
 Bloc S.A.E. à T..... B.T.....
 S.A.E. T - block..... B.T.....



BLOCCO S.A.E. A T PER FLANGE

S.A.E. T block counter flange
 Contre bloc S.A.E. à T
 S.A.E. T block gegenflanschausführung

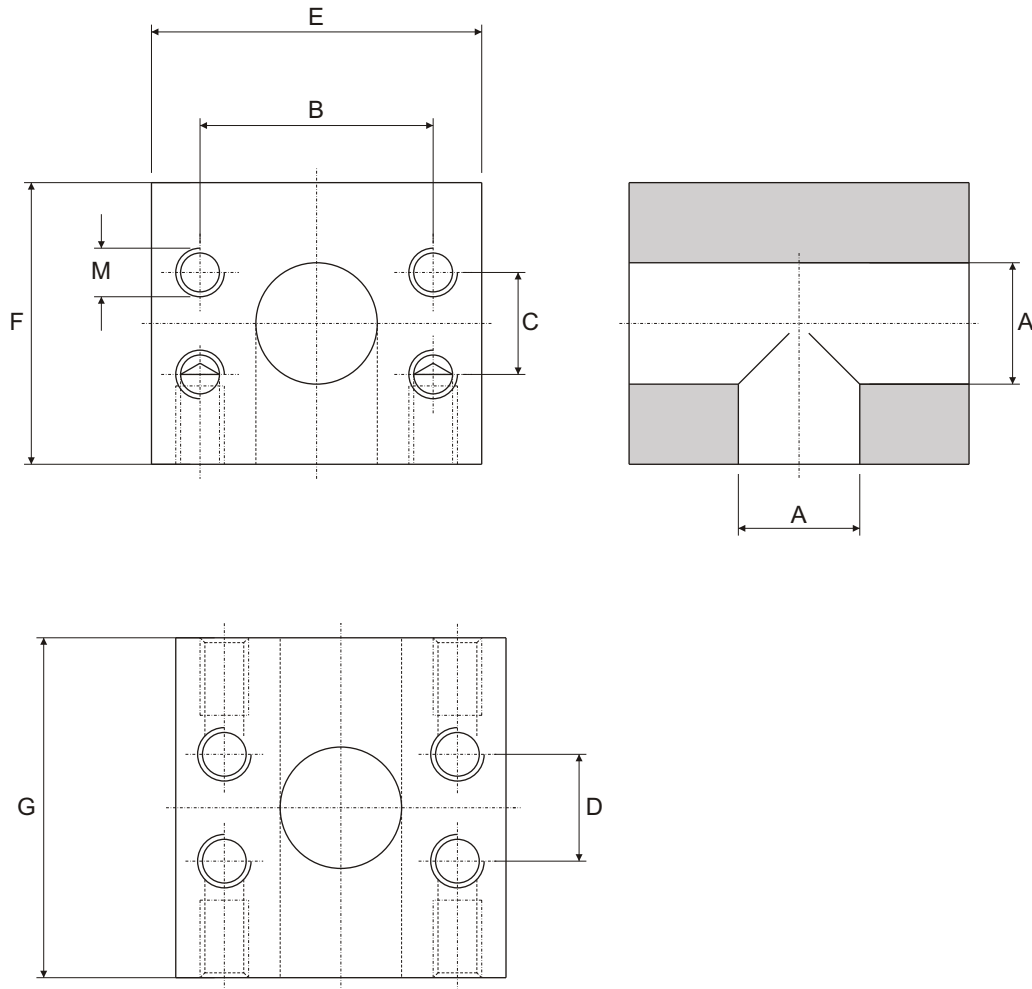

serie 6000 psi

Pressione max esercizio bar	Tipo Type	S.A.E.	A	B	C	D	E	F	G	M
420	B.T.F.F. - 600-600	$\frac{3}{4}$ "	19	50,8	23,8	23,8	70	55	70	M10
420	B.T.F.F. - 602-602	1"	25	57,1	27,8	27,8	80	69	80	M12
420	B.T.F.F. - 604-604	1" $\frac{1}{4}$	30	66,7	31,6	31,6	94	75	94	M14
420	B.T.F.F. - 606-606	1" $\frac{1}{2}$	38	79,4	36,5	36,5	106	100	106	M16
420	B.T.F.F. - 608-608	2"	50	96,8	44,4	44,4	135	116	140	M20

Per ordinazione: / Ordering Examples: / Pour commander: / Bestellbeispiel:

Blocco S.A.E. a T per flange B.T.F.F.....
 S.A.E. T block counter flange B.T.F.F.....
 Contre bloc S.A.E. à T B.T.F.F.....
 S.A.E. T - block gegenflanschausführung B.T.F.F.....



FLANGE S.A.E. PER CONTROLLO DI PRESSIONE

**Chek pressure
S.A.E. flange
Bride S.A.E. pour le contrôle
de la pression
S.A.E.-Zwischenflansch
mit Messanschluss**

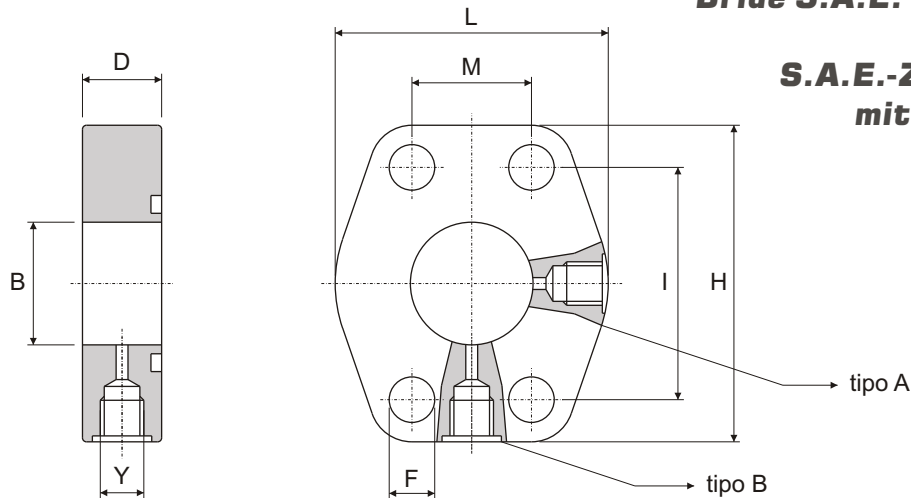

La misura "D" e "Y" può essere variata a seconda delle esigenze del cliente.
Measurement "D" and "Y" can be changed according to customer's requests.
La mesure "D" et "Y" peut être changé selon les exigences de la clientèle.
Auch für andere abmessungen "D" und "Y" nach vorgabe Lieferbar.

serie 3000 psi

Pressione max esercizio bar	Tipo Type	A S.A.E.	B	D	F	H	I	L	M	Y	OR O-RING
348	DST 102	1"	25	19	11	71	52,4	53	26,2	M10-G18	4131
278	DST 104	1" 1/4	31	20	11,5	80	58,7	69	30,2	M10-M12-G18	4150
210	DST 106	1" 1/2	38	25	13,5	94	69,85	77	35,7	M10-M12-M14-G18-G14	4187
210	DST 108	2"	50	25	13,5	103	77,8	89	42,9	M10-M12-M14-G18-G14	4225
175	DST 110	2" 1/2	63	25	13,5	115	89	101	50,8	M10-M12-M14-G18-G14	4275
138	DST 112	3"	73	27	17	135	106,4	124	62	M10-M12-M14-M16-G18-G14-G38	4337
35	DST 114	3" 1/2	89	27	17	152	120,7	136	70	M10-M12-M14-M16-G18-G14-G38	4387
35	DST 116	4"	99	26	17	162	130	146	77,8	M10-M12-M14-M16-G18-G14-G38	4437
35	DST 118	5"	120	23	17	184	152,4	180	92	M10-M12-M14-M16-G18-G14-G38	4537

serie 6000 psi

Pressione max esercizio bar	Tipo Type	A S.A.E.	B	D	F	H	I	L	M	Y	OR O-RING
420	DST 403	1"	25	22	13	80	57,1	69	27,8	M10-M12-G18	4131
420	DST 404	1" 1/4	31	26	15	94	66,7	77	31,6	M10-M12-G18	4150
420	DST 405	1" 1/2	38	30	17	106	79,4	89	36,5	M10-M12-M14-G18-G14	4187
420	DST 406	2"	50	36	21	135	96,8	116	44,4	M10-M12-M14-M16-G18-G14-G38	4225
420	DST 408	2" 1/2	63	45	25	166	123,8	150	58,7	M10-M12-M14-M16-G18-G14-G38	4275
420	DST 410	3"	73	55	32	208	152,4	178	71,4	M10-M12-M14-M16-G18-G14-G38	4337

Tipo Type	Dimensioni - Dimensions				
	Y	X	K	W	Z
M10	M10 x 1	15	8	1,5	13,5
M12	M12 x 1,5	18	12	1,5	18,5
M14	M14 x 1,5	20	12	1,5	18,5
M16	M16 x 1,5	22	12	1,5	18,5
G18	G ¹ / ₈ "	15	10	1,5	16,5
G14	G ¹ / ₄ "	19	12	1,5	18,5
G38	G ³ / ₈ "	23	13	1,5	18,5

Per ordinazione flange: / Ordering Examples: / Pour commander brides: / Bestellbeispiel für Flansche:

Solo flangia.....DST...*(+MA/MB/GA/GB...)
Only flange.....DST...*(+MA/MB/GA/GB...)
Seulement bride...DST...*(+MA/MB/GA/GB...)
Nur Flansch.....DST...*(+MA/MB/GA/GB...)



FLANGE E CONTROFLANGE S.A.E. con foro controllo pressione

— SAE flanges and counterflanges
with hole to chek pressure on
Bride et contre bride S.A.E.
avec trou de contrôle de pression
SAE flansch und Gegenflansch
mit Messanschluss

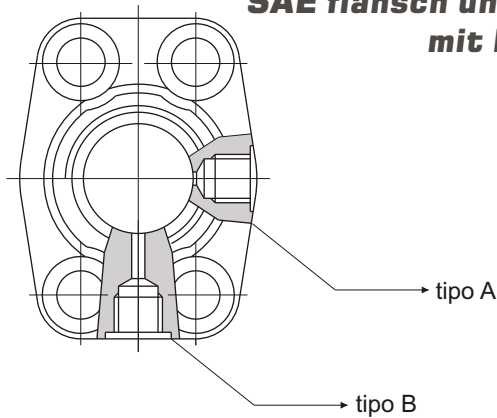
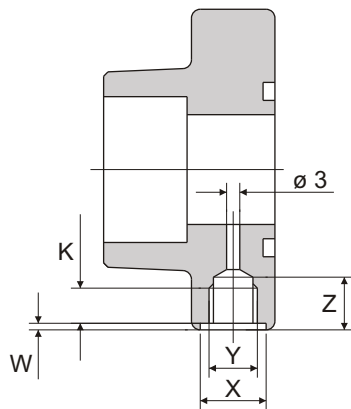

La misura "Y" può essere variata a seconda delle esigenze del cliente.
Measurement "Y" can be changed according to customer's requests.
La mesure "Y" peut être changé selon les exigences de la clientèle.
Auch für andere abmessungen "Y" nach vorgabe Lieferbar.

serie 3000 psi

Pressione max esercizio bar	Tipo Type	S.A.E.	Foro eseguibile Hole could made on
348	P.CFS/P.C102	1"	M10-G18
278	P.CFS/P.C104	1" 1/4	M10-M12-G18
210	P.CFS/P.C106	1" 1/2	M10-M12-M14-G18-G14
210	P.CFS/P.C108	2"	M10-M12-M14-G18-G14
175	P.CFS/P.C110	2" 1/2	M10-M12-M14-G18-G14
138	P.CFS/P.C112	3"	M10-M12-M14-M16-G18-G14-G38
35	P.CFS/P.C114	3" 1/2	M10-M12-M14-M16-G18-G14-G38
35	P.CFS/P.C116	4"	M10-M12-M14-M16-G18-G14-G38
35	P.CFS/P.C118	5"	M10-M12-M14-M16-G18-G14-G38

serie 6000 psi

Pressione max esercizio bar	Tipo Type	S.A.E.	Foro eseguibile Hole could made on
420	P.CFS/P.C403	1"	M10-M12-G18
420	P.CFS/P.C404	1" 1/4	M10-M12-G18
420	P.CFS/P.C405	1" 1/2	M10-M12-M14-G18-G14
420	P.CFS/P.C406	2"	M10-M12-M14-M16-G18-G14-G38
420	P.CFS/P.C408	2" 1/2	M10-M12-M14-M16-G18-G14-G38
420	P.CFS/P.C410	3"	M10-M12-M14-M16-G18-G14-G38

Tipo Type	Dimensioni - Dimensions				
	Y	X	K	W	Z
M10	M10 x 1	15	8	1,5	13,5
M12	M12 x 1,5	18	12	1,5	18,5
M14	M14 x 1,5	20	12	1,5	18,5
M16	M16 x 1,5	22	12	1,5	18,5
G18	G ¹ / ₈ "	15	10	1,5	16,5
G14	G ¹ / ₄ "	19	12	1,5	18,5
G38	G ³ / ₈ "	23	13	1,5	18,5

Per ordinazione flange: / Ordering Examples: / Pour commander brides: / Bestellbeispiel für Flansche:

Flangia...PCFS/PC...*(+M/MB/GA/GB...) Con viti UNC, rondelle e OR.....PCFS/PC...*U(+M/MB/GA/GB...) Con viti metriche, rondelle e OR.....PCFS/PC...*M(+M/MB/GA/GB...)
 Flange...PCFS/PC...*(+M/MB/GA/GB...) With UNC screws, washers and o-ring.....PCFS/PC...*U(+M/MB/GA/GB...) With metrical screws, washers and o-ring...PCFS/PC...*M(+M/MB/GA/GB...)
 Bride...PCFS/PC...*(+M/MB/GA/GB...) Avec vis UNC, rondelles et OR.....PCFS/PC...*U(+M/MB/GA/GB...) Avec vis métriques, rondelles et OR.....PCFS/PC...*M(+M/MB/GA/GB...)
 Flansch...PCFS/PC...*(+M/MB/GA/GB...) Mit UNC-Schrauben, O-Ring und Federringen...PCFS/PC...*U(+M/MB/GA/GB...) Mit met-schrauben, O-Ring und Federringen...PCFS/PC...*M(+M/MB/GA/GB...)
 (* = S/ST/G/N) (* = S/ST/G/N) (* = S/ST/G/N)

FLANGE OVALI

**Oval flanges
Bride ovale
Ovale flansche**

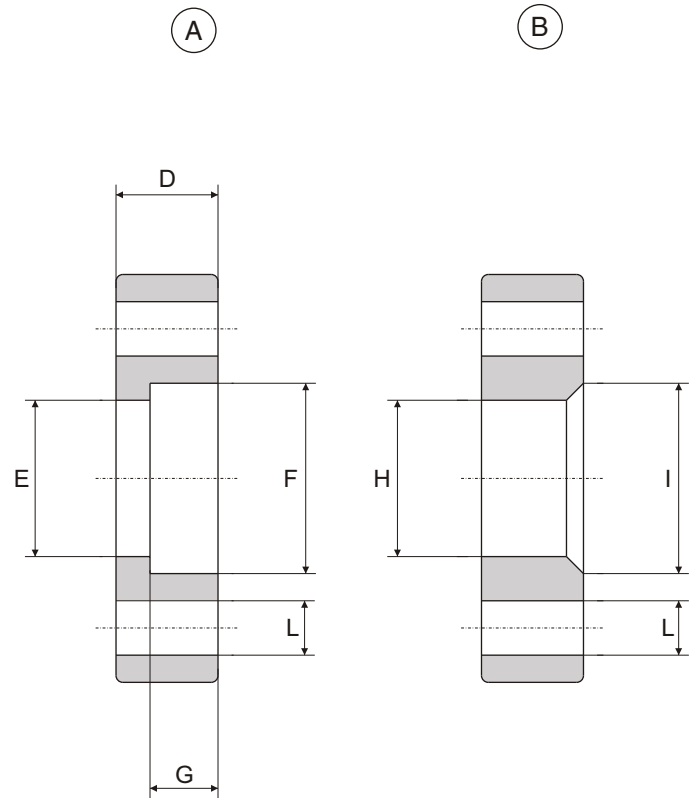
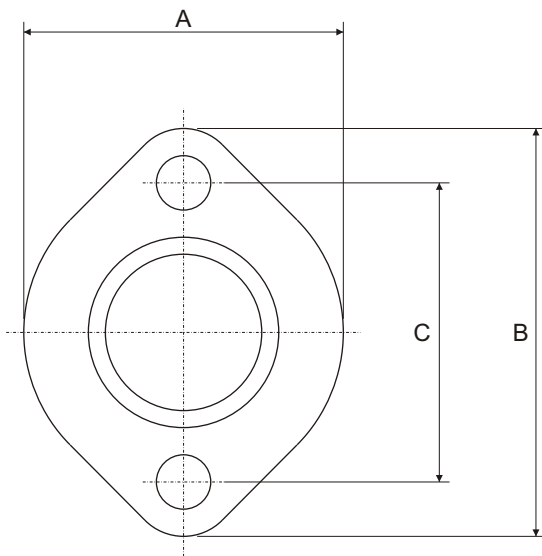

serie 6000 psi

Tipo Type	S.A.E.	A	B	C	D	E	F	G	H	I	L
F010821	1/2"	48	60	44,4	14	21,15	26,1	9,4	20	23,5	8,4
F011024	1/2"	48	60	44,4	14	24,1	28,1	9,4	23,5	27	8,4
F011230	3/4"	60	76	56,1	18	30,1	37,1	11	27,5	32	10,5
F011636	1"	70	88	63,6	22	36,5	44,15	14	37,5	43	12,5
F012040	1" 1/4	78	103	73,9	25	40,5	50,2	17	44	50	14,5

Per ordinazione flange FO...A
FO...B
Ordering Examples FO...A
FO...B

Pour commander FO...A
FO...B
Bestellbeispiel für flansche mit schrauben FO...A
FO...B